



**HEAVY HARROW
HH-8200**

**OPERATORS MANUAL
& PART LIST**

QUICK START GUIDE

HYDRAULIC CONNECTIONS TO TRACTOR

YELLOW – Wing lift/lower

RED – Tine angle adjust

GREEN – Wing wheel pivot

UNFOLD TO FIELD POSITION

- **IMPORTANT:** Ensure the center harrow section has been rotated forward after shipping and bolted in place or damage to the unit may result.
- Find a location that is as level as possible. Position harrow in line with tractor.
- Remove lock pins from wing lift and wing pivot wheels.
- From the cab of the tractor, rotate pivot wheels to 45° (**GREEN** hydraulic remote).
- Slowly back up the tractor to unfold.
- Once wings are nearly fully unfolded, rotate pivot wheels to 90°.
- Ensure that the draft arms have pushed the swing arms into the lock mechanism.
- Carefully lower the harrow wing halfway to the ground (**YELLOW** hydraulic remote). Ensure that the swing arms are both still locked in place.
- Slowly drive the tractor ahead, while lowering the harrow wing the rest of the way down.

NOTE:

- **IMPORTANT:** Do not lower the harrow wings fully down to the ground without driving ahead simultaneously. Damage to your rotary harrow sections could result.
- Check the level of A-frame hitch relative to the tractor. Adjust using hitch tongue to level
- Ensure all harrow chains are tight. Tighten chains using the tools provided on the left-most rotary harrow section if necessary.

CONTENTS

SECTION 1	PAGE
INTRODUCTION	1
MANUAL & EQUIPMENT DETAILS	2
PRE-DELIVERY INSPECTION	3
SPECIFICATIONS	4
SERVICE & WARRANTY POLICY	5, 6
SAFETY RECOMMENDATIONS	7
DECAL LOCATIONS	9, 10
MAINTENANCE	11-13
OPERATING INSTRUCTIONS	14-21
GRADE CHART	22
TORQUE CHART	23

SECTION 2	PAGE
PARTS	2-25
WHEEL HUBS	26-27
HYDRAULICS	28-33
CYLINDERS	34-43

SECTION 1

INTRODUCTION

Thank you for making the decision to purchase a RITE WAY product!

We are pleased to welcome you as an owner of a product from **RITE WAY MFG.** This machinery is the culmination of years of agricultural and engineering experience and has been designed to deliver you with many years of successful operation service.

For the most efficient operation of your **HH-8200** we have provided this owner's manual. In this manual we have included proper maintenance and functional procedures to offer maximum longevity for your new equipment. Before operating we urge a careful study of this manual to provide a thorough understanding of your new **HH-8200**. We also recommend that you take care of this manual so it will be available for future reference. Should your manual become lost or destroyed a new copy can be obtained from your **Rite Way Manufacturing** dealer. We will also be happy to answer any questions you might have concerning the use or care of this product.

Rite Way Manufacturing Co. Ltd.

P.O. Box 328

Imperial, Saskatchewan, Canada

S0G 2J0

PH: 306-963-2180

Fax: 306-963-2660

Web Site: www.ritewaymfg.com

Email: info@ritewaymfg.com

MANUAL INFORMATION

Unit Model Number	HH-8200
Manual Revision Number	4.2
Manual Revision Date	April 21, 2021
Manual Serial Number Range	21-0086 and up

The area below is provided for the owner / end-user to make notes regarding the equipment.

Serial Number of Unit	
Date of Purchase	
Dealer Name	
Dealer Address	
Dealer Phone Number	
Salesman Name	
Salesman Phone Number	
Notes	

PRE-DELIVERY INSPECTION

GENERAL

- Remove wrapping and wash unit, removing all road debris. (Road salt, mud, snow, etc.)
- Inspect paint, decals and general appearance of unit.
- Verify that the owners manual is in the manual storage tube.
- Verify 'SLOW MOVING VEHICLE' sign (SMV) is on unit
- Verify that jacks are with the unit and function properly.
- Check wheel bolts for proper torque.
- Check for proper tire pressure (PSI).
- Verify that the wheel hubs are lubricated.
- Verify that locking pins and / or ram locks are in place.
- Lubricate all components as per operators manual recommendation.
- Check that all bolts and fasteners are at the proper torque specifications.

(NOTE: All cap screws that have lock nuts joining moving pieces should not be tightened completely, they must allow movement. i.e. Spring pressure kits, rock shaft connector, draft arm, etc.

- Check sprocket alignment and chain tension. (If applicable)
- Check locking collars and set screws for proper tension. (If applicable)
- Verify operation of lights. (If applicable)
- Verify the unit moves 'IN' and 'OUT' of transport without any binding.
- Verify that tires are tracking properly when in transport mode.

HYDRAULICS

- Insure that all hydraulic hoses and lines are routed properly and secured.
- Verify that all hydraulic fittings / hoses are secure and there are no oil leaks.
- Inspect all cylinders for leakage and the cylinder shaft for rust, pits, or scratches.
- Verify operation of all hydraulic functions - Cycle hydraulic cylinders to remove air from the system.

DELIVERY

- Verify that 'The customer is aware of warning decals and proper jack placement for transport.'
- Verify that 'The customer is aware of proper operation and transportation of the unit'.
- Verify that 'The customer has received an operators manual'.
- Explain all maintenance and service intervals to the customer (From operators manual).
- Advise the customer of grease zerk locations and maintenance schedules.
- Level the unit per operators manual and instruct the customer on the proper procedures.
- Verify that the center harrow section has been rotated to working position.

Pre-delivery Inspection Completed By (Sign Below)

Pre-delivery Inspection Confirmed By (Sign Below)

SPECIFICATIONS

GENERAL INFORMATION

- 40° to 85° Hydraulic Tine Angling From Tractor Cab
- 9/16" x 28" Harrow Tines
- Auto Fold With Rite Way Hydraulic Pivot Wheel System
- 5 Bars - 18" (460mm) Spacing Between Rows- 2-3/8" Diameter Pipe
- 15 Double Tines; APPROX. 2.75" Tine Spaces (6-1/2' Harrow)
- 25 Double Tines; APPROX. 2.75" Tine Spaces (11' Harrow)
- Self-Levelling Parallel Linkage
- Two Stage Adjustable Harrow
- Spring Adjustable Harrow Down Pressure
- Adjustable Hitch Height c/w Perfect Hitch Clevis
- Light Kit

MAIN FRAME

- Heavy duty universal joint pivots
- 8" x 4" x 1/4" Wall A-Frame Tube
- Tires - 16.5L x 16.1 - 10PLY

HYDRAULIC SYSTEM

- Standard unit requires - 6 Hydraulic Banks.
- Heavy duty hydraulic cylinders.
- Zinc plated steel hydraulic lines

WINGS

- 8" x 8" x 3/8" Wall Wing Tube (55' and up), and Centre Bar
- Tires - 12.5L x 15 - 8PLY (68' and up)

OPTIONS

- Valmar granular applicator mounting kit
- Acremeter kit
- 5/8" x 28 Harrow Tine
- 9/16" x 28 Carbide Tip Harrow Tine
- 5/8" x 28 Carbide Tip Harrow Tine

Technical Information	8245	8255	8268	8278
Working Width	45' (13.7m)	55' (16.8m)	68' (20.7m)	78' (23.8m)
No. of Harrow Sections	5	5	7	7
Transp. Width	14' 9" (4.5m)	14' 9" (4.5m)	14' 8" (4.5m)	14' 6" (4.4m)
Transp. Height	11' 8" (3.6m)	11' 8" (3.6m)	11' 8" (3.6m)	11' 8" (3.6m)
Transp. Length	40' 6" (12.3m)	44' 8" (13.6m)	51' 8" (15.7m)	55' 10" (17.0m)
Approx. Weight (lbs/kg)	10,100 / 4,581	11,950 / 5,420	13,560 / 61,51	14,720 / 6,677

SERVICE & WARRANTY POLICY

Rite Way Manufacturing Co. Ltd. (hereafter referred to as Rite Way) warrants each new machine to be free from defects in materials and workmanship for a period of one (1) year from date of purchase under normal agricultural use and service. In addition, Rite Way will supply at no charge, (F.O.B Rite Way Factory) any part that has failed within the 2nd year. Rite Way's obligation under this warranty is limited to the repair or replacement of any defective parts of the equipment at its own discretion.

Any alterations, modifications or additions done to a finished product will **void this warranty** unless prior written permission from Rite Way is obtained.

Items that are not manufactured by Rite Way are covered by the warranty of the supplier of these items. We will therefore extend, without assuming any responsibility, any warranty given to us by our suppliers.

This warranty shall not apply to any machine, that in the company's judgment has been subjected to misuse, negligence or accident. In no event shall the owner be entitled to recover costs for incidental, special or consequential damages such as, but not limited to; Loss of crop, loss of profit or revenue, other commercial losses, inconvenience or rental costs.

This warranty shall not apply unless Rite Way or its designated dealer is promptly notified of claimed defects and the allegedly defective part is held for inspection.

Repair parts purchased for machines 'Out of Warranty', are warranted to be free from defects in material and workmanship under normal use and service for a period of ninety (90) days from the date of delivery to the customer.

The warranty shall only become valid when delivery notification for warranty is received by Rite Way within 20 days of the completion of sale.

OWNER'S / USERS OBLIGATION: It is the responsibility of the user to read the Operators Manual and understand the safe and correct operating procedures as it pertains to the operation of the product, and to lubricate and maintain the product according to the maintenance schedule in the Manual.

The user is responsible for inspecting the machine, and for having parts repaired or replaced when continued use of the product could cause damage or excessive wear to any other parts. It is the user's responsibility to deliver their machine to a Rite Way dealer for service or replacement of defective parts which are covered by the standard warranty.

Rite Way **will not** be held responsible for charges such as transportation, fuel, lodging when a dealer / dealer representative travels to a customer location for warranty or inspection.

SERVICE & WARRANTY CLAIM PROCEDURE

1. All claims must be handled through a dealer / distributor. All claims must be submitted on a properly completed claim form within 30 days of the date of repair.
2. A warranty registration claim form must be on file at Rite Way Mfg. to validate a warranty claim.
3. Defective parts are to be held at the dealer / distributor's place of business until the warranty claim form has been processed. Rite Way will advise when parts can be released.
4. Parts that require inspection by Rite Way personnel must be accompanied by a Return Goods Form number, and must be sent by pre-paid freight. Rite Way will refund pre-paid freight charges on any items determined to be defective.
5. Rite Way will not assume responsibility for repairs or expenses incurred without authorization. Warranty labour in excess of \$150.00 must be authorized before such work is performed and photographs before and after repairs are required.
6. Warranty labour is to be claimed on the warranty claim form, only if the warranty labour was performed by the dealer. Travel time is not covered by warranty and should not be included. Rite Way reserves the right to adjust or allocate labour times and values based on its experience.
7. It is the responsibility of the dealer to ensure that the warranty registration forms are properly completed and returned to Rite Way Mfg., Imperial, SK.

SAFETY RECOMENDATIONS

1. Read manual thoroughly before operating machine.
2. Study all warning decals on implement.
3. Most accidents occur because of neglect or carelessness.
4. Do not allow riders on the tractor or implement during operation.
5. Do not allow children on or near the machine.
6. Connect the implement hitch to the tractor before operating the hydraulic system.
NOTE: Be aware of any hydraulic leaks.
7. Always throttle the tractor down and use caution when connecting the implement to the tractor hitch.
NOTE: Never stand between the tractor and implement.
8. Lower the hitch jack onto firm ground and chock the tires when un-hooking implement from tractor.
NOTE: Ensure the unit is on level ground prior to un-hooking tractor.
9. Exercise extra caution when working on hillsides or near ditches.
10. Ensure that the tractor draw-bar is pinned during transport.
11. Maximum speed while transporting the **HH-8200** is 25 mph (40 km/h).
12. Ensure that the **HH-8200** frame is lowered to the ground before doing any work on machine.
NOTE: If it is necessary to work on machine with the drawbar raised, ensure that cylinders are locked in position using the lock pin.
13. Do not work on this machine when hydraulic system is under pressure.
14. Observe all laws and regulations when transporting unit on public roads.
15. Do not transport this machine on public roads unless all safety & maintenance checks have been completed.
16. Ensure the tires are inflated to the correct pressure:
11L-15 (Wings): 90 psi
12.5L-15 (Wings): 90 psi
16.5 x 16.1 (Center Frame): 35 psi

This machine will provide years of trouble-free & safe operation IF all maintenance and safety instructions are followed.

PAGE INTENTIONALLY LEFT BLANK

DECAL LOCATIONS

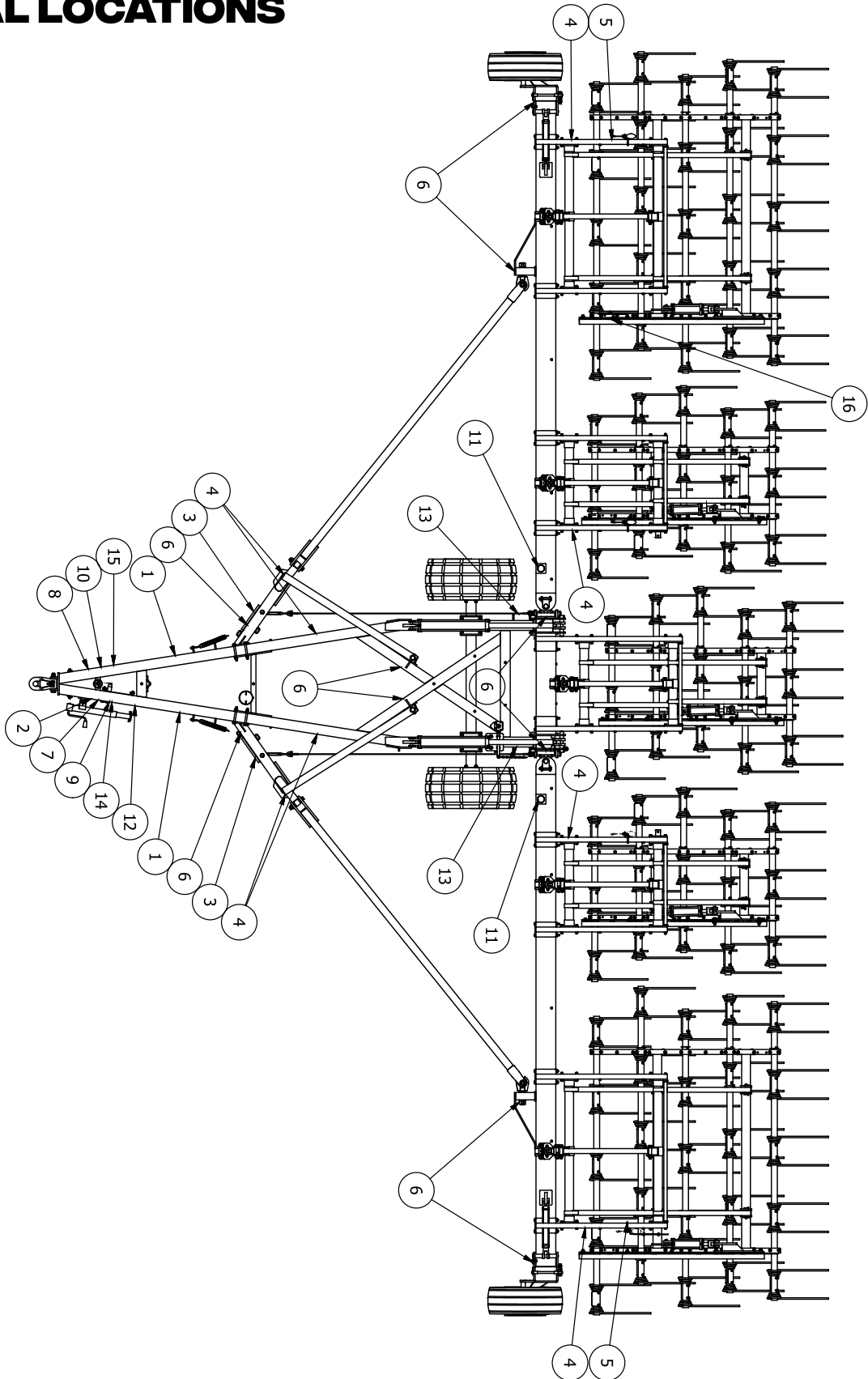

DECAL LOCATIONS

ITEM #	PART #	DESCRIPTION	QTY
1	060-0121	Rite Way Mfg. (Large Decal)	2
2	060-0038	Attention - Ensure That All Cylinders Are Retracted...	1
3	060-0125	HH-8200 - (3" x 11")	2
4	060-0009	Amber Reflector (3 x 2)	14
5	060-0022	Red Reflector (3 x 2)	2
6	060-0046	Grease Every 8 Hours	10
7	060-0015	Important - Block Wheels...	1
8	060-0028	Warning - Lower or Block Elevated Components	1
9	060-0011	Caution - Escaping Fluid Hazard...	1
10	060-0029	Warning - Stand Clear of Hitch Tongue...	1
11	060-0036	Place Jack in Small Mount for Transport...	2
12	060-0034	Rite Way Serial Number Plate	1
13	060-0050	Warning - Tine Angling Cylinders...	2
14	060-0061	Hydraulic - Hose Application	1
15	060-0067	Warning - Check and tighten hub and wheel bolts..	1
16	060-0091	Tine Angle Indicator - (1234) 11 x 2-3/4"	1
17	060-0108	www.ritewaymfg.com - (1" x 20")	2

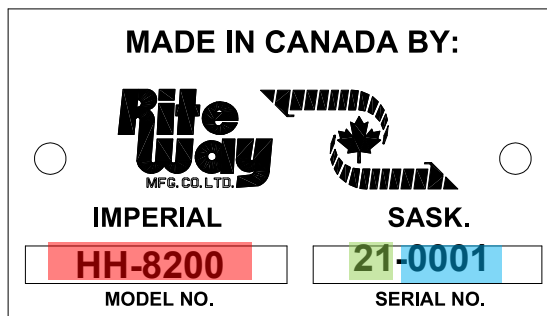

UNIT SERIES
MODEL YEAR
UNIT NUMBER

MAINTANENCE

GENERAL

- Repack the wheel hubs after the first 500 kilometres of travel ; then yearly thereafter.
- Visually inspect the wheel bolts for tightness each day. Torque to 110 ft lbs. (149 Nm) after the first few hours of operation and frequently thereafter.

- Ensure the tires are inflated to the correct pressure:

11L-15 (Wings): 90 psi

12.5L-15 (Wings): 90 psi

16.5 x 16.1 (Center Frame): 35 psi

EVERY 8 HOURS (DAILY)

- Grease all pins and knuckles. (See decals locations)
- Grease harrow chain bearings.

EVERY 100 HOURS (MONTHLY)

- Visually inspect hydraulic hoses & fittings for leaks or damage.

ANNUALLY

- Inspect wheel bearings / hubs for tightness and grease.
- Check wheel bolts for tightness and re-torque.
- Visually inspect unit for loose, worn or damaged components.

STORAGE

- Coat any exposed cylinder shafts with thick oil or grease.
- Ensure that parking jacks are situated on firm ground. Failure to do so may cause the hitch to rise sharply as the jack pads sink into the ground.
- Lock all applicable safety pins into place.

NOTE: All fasteners with locknuts that are used to join moving pieces should not be tightened completely to allow for movement.

MAINTENANCE – GREASE LOCATIONS

Grease should be applied to both sides of the machine.

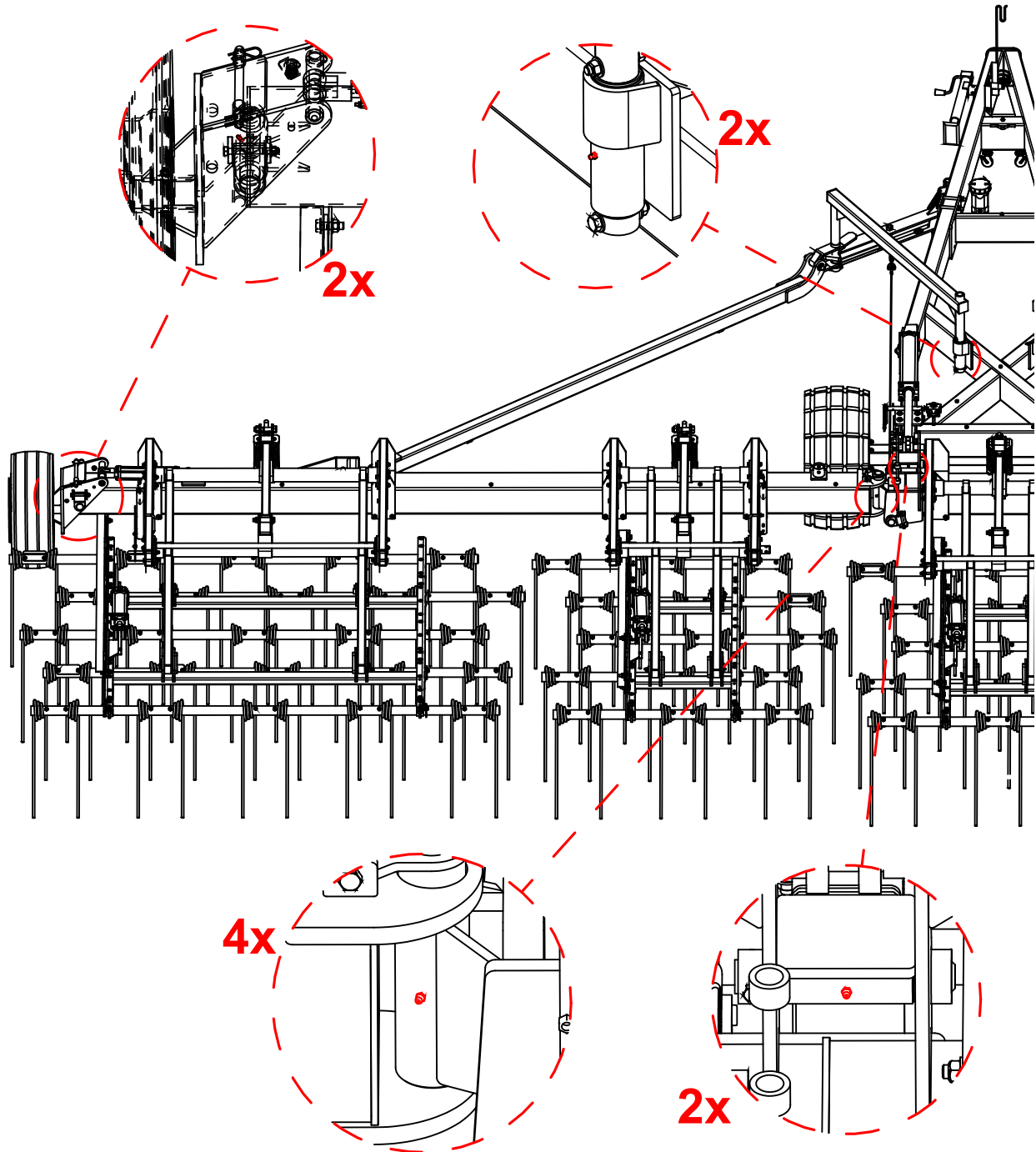

MAINTENANCE – GREASE LOCATIONS

Grease should be applied to both sides of the machine.

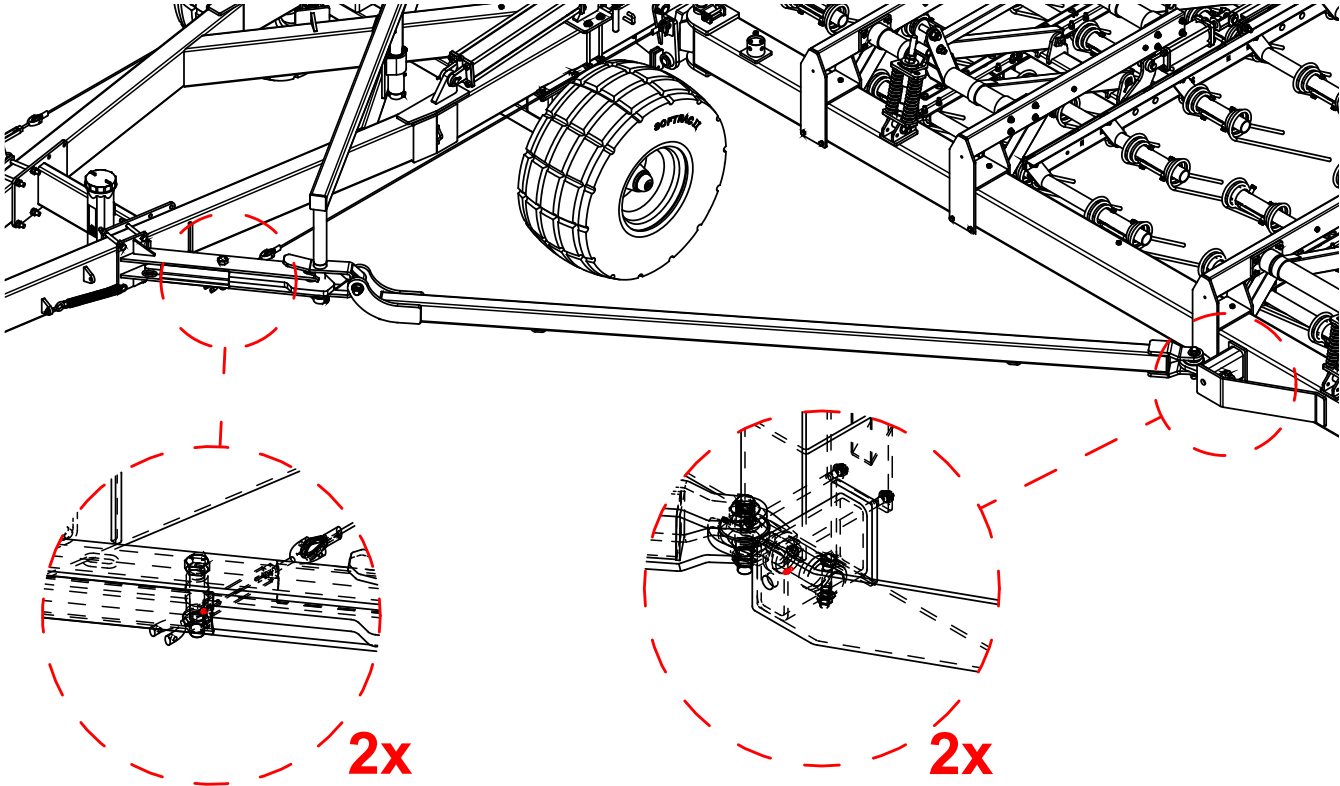

OPERATING INSTRUCTIONS

GENERAL INFORMATION

- In transport position, the maximum turning angle is 40°. Turning too tight will cause severe damage to the machine.
- Always choose a level area when folding the unit in or out of transport mode.
- Lubricate all pins, axles and bearings regularly to prevent premature failure.
- Clean hydraulic hose ends prior to coupling with tractor hydraulic system.
- The **HH-8200** requires three sets of hydraulic remotes to operate the machine, further detailed in this section.

TRACTOR HOOK-UP

- Move the tractor into position where the pin can be inserted into the draw bar hitch (fig. 1).
- If the hitch is too high, you can lower the hitch by adjusting the jack(s) on the wings.
- Retract the hitch parking jack and pin up in the sideways position
- Retract the wing parking jack(s) and pin in storage stub on harrow lift arm

NOTE: Use a clevis-type tractor hitch with a retained type of hitch pin.

NOTE: Ensure that the parking jack handle is secured by chain prior to moving the machine. Failure to do so can destroy the jack handle.

- Hook up the three hydraulic circuits to your tractor remote.

Recommended Hydraulic Connections:

RED – Remote 1 – Tine angle adjust

YELLOW – Remote 2 – Wing lift/lower

GREEN – Remote 3 – Wing wheel pivot

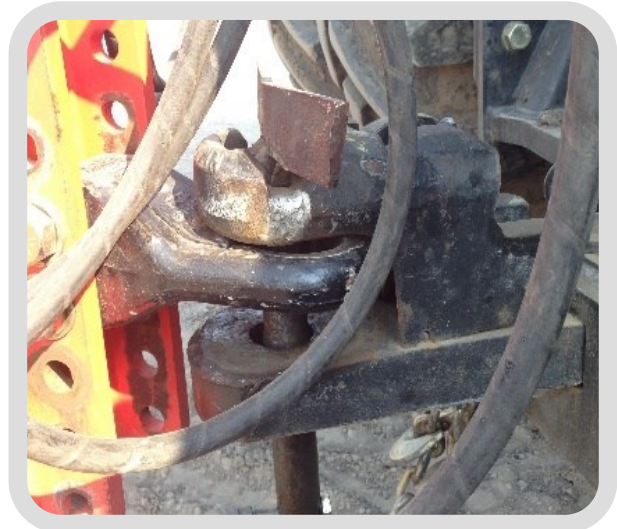

FIGURE 1

CAUTION

- Always choose a level area when folding unit either to or from transport position.
- Lubricate all pins, axles and bearings regularly to prevent premature failure of components.

OPERATING INSTRUCTIONS

TRANSPORT TO FIELD POSITION

1. Hook up harrow according to prior instructions.
2. Ensure that the safety pins are in transport position before towing on the road.
3. When entering the field from transport mode, find a level location.
4. Position the machine in-line with the tractor and bring the tractor to a full stop.
5. Remove both wheel pivot safety pins from transport position to field position and secure (fig. 2).
6. Remove the main lift safety pin (fig. 3).

NOTE: Failing to follow this procedure may cause severe damage to the machine.

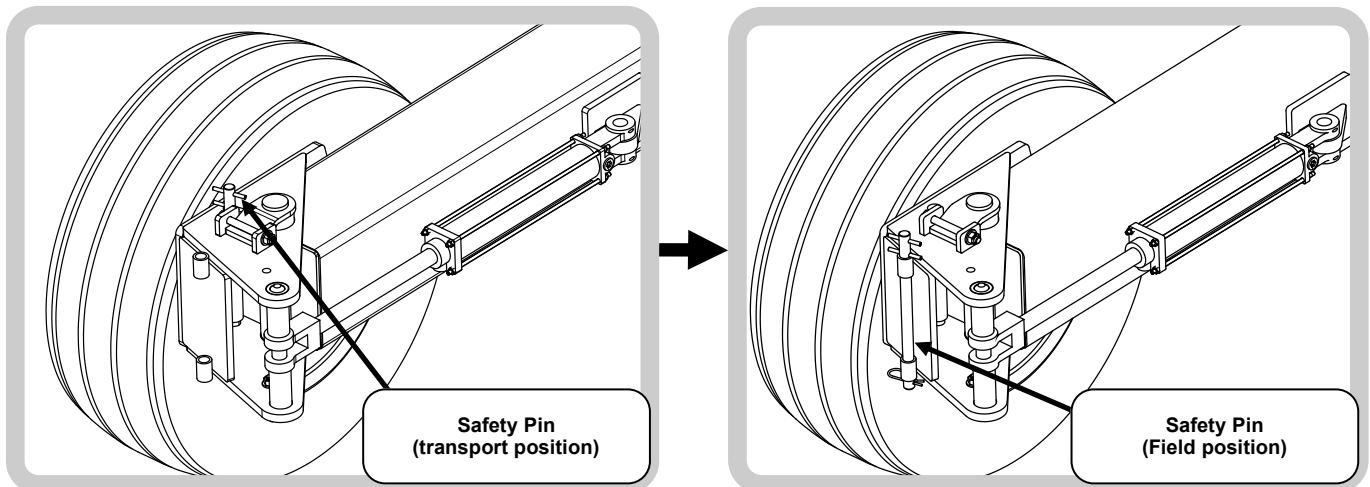

FIGURE 2

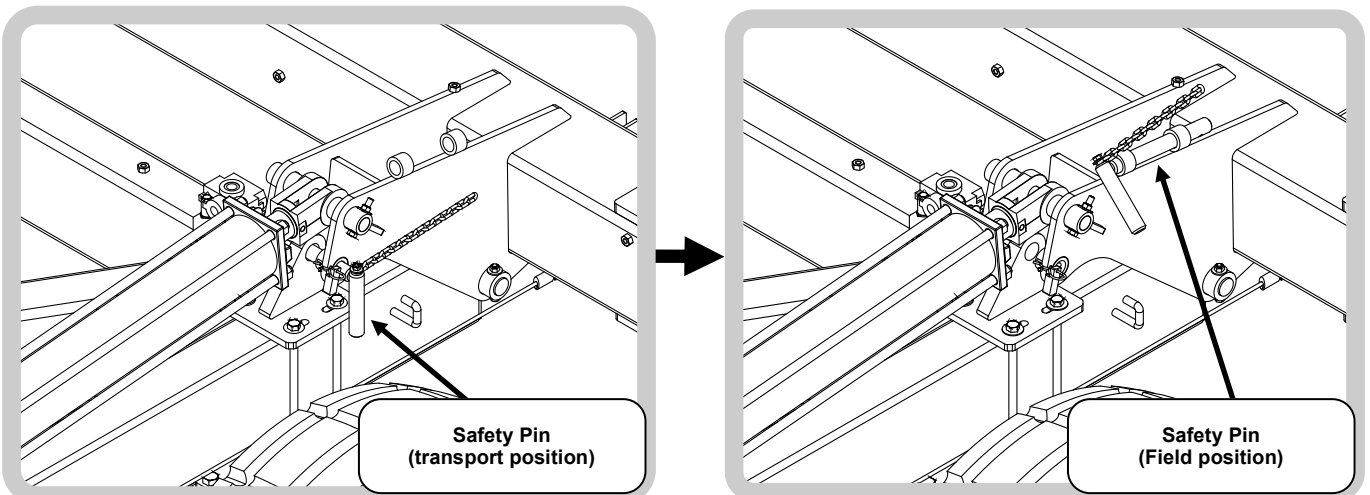

FIGURE 3

OPERATING INSTRUCTIONS

TRANSPORT TO FIELD POSITION

7. From the cab of the tractor, rotate pivot wheels to 45° (**GREEN** hydraulic remote) (fig. 4).
8. Slowly back up the tractor to unfold (fig. 5).
9. Once wings are nearly fully unfolded, rotate pivot wheels to 90°.

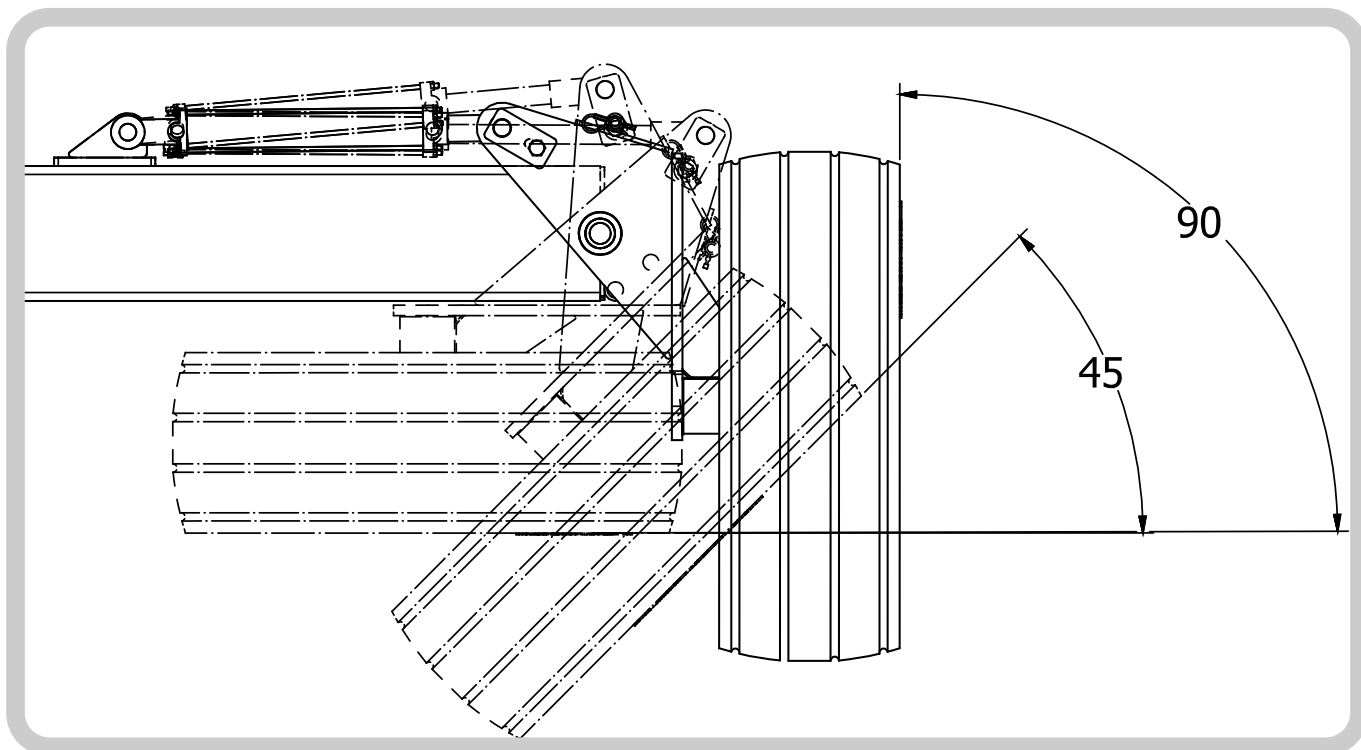

FIGURE 4

OPERATING INSTRUCTIONS

TRANSPORT TO FIELD POSITION

10. Ensure that the draft arms have pushed the swing arms into the lock mechanism (fig. 6).
11. Carefully lower the harrow wing halfway to the ground (**YELLOW** hydraulic remote). Ensure that the swing arms are both still locked in place.
12. Slowly drive the tractor ahead, while lowering the harrow wing the rest of the way down (fig. 7).

NOTE:

- Do not lower the harrow wings fully down to the ground without driving ahead simultaneously. Damage to your Heavy harrow sections could result.
- Check the level of A-frame hitch relative to the tractor. Adjust using hitch tongue to level
- Ensure all harrow prongs are tight.

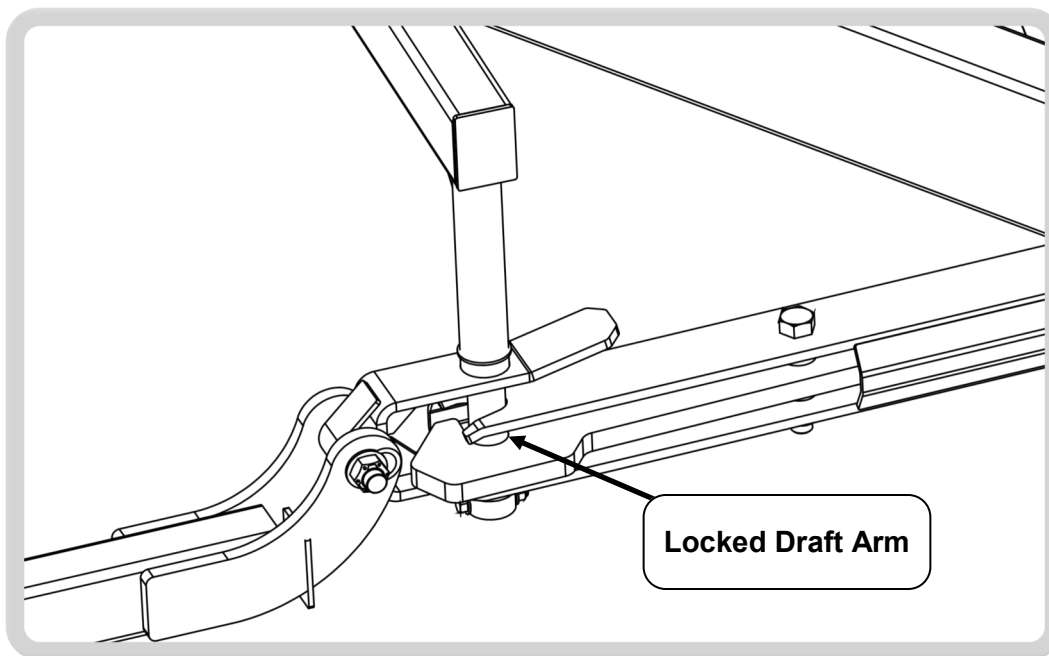

FIGURE 6

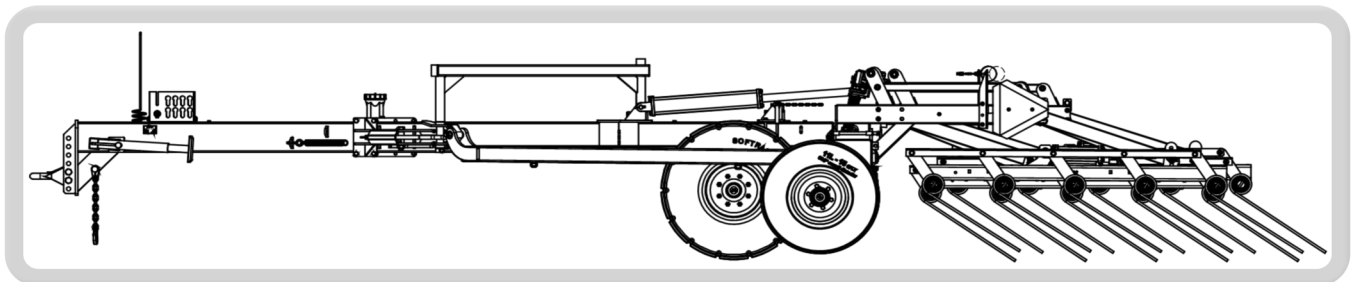

FIGURE 7

OPERATING INSTRUCTIONS

FIELD TO TRANSPORT POSITION

1. Stop the tractor before attempting to fold up the harrow toolbar.
2. Lift up the wings by activating the **YELLOW** hydraulic remote. Ensure the auto fold lock opens as the harrows are lifted to the raised position (fig. 8).
3. Turn the wing pivot wheels 90° using the **GREEN** hydraulic remote so that they are parallel to the wings.
4. Slowly drive forward to fold back wings.
5. Retract the tine adjust cylinders using the **RED** hydraulic remote to lower the harrow sections.
6. If you intend to disconnect the harrow from the tractor, line up the harrow with the tractor so that the parking jacks will not interfere with the draft arms.
7. Lock the wing lift and wing wheel cylinders with transport pins.
8. **Ensure the Main Lift transport pin is properly engaged. The roll pin must be locked into the tab in the frame and cotter pin installed (fig 9). If this is not properly engaged DAMAGE WILL OCCUR.**

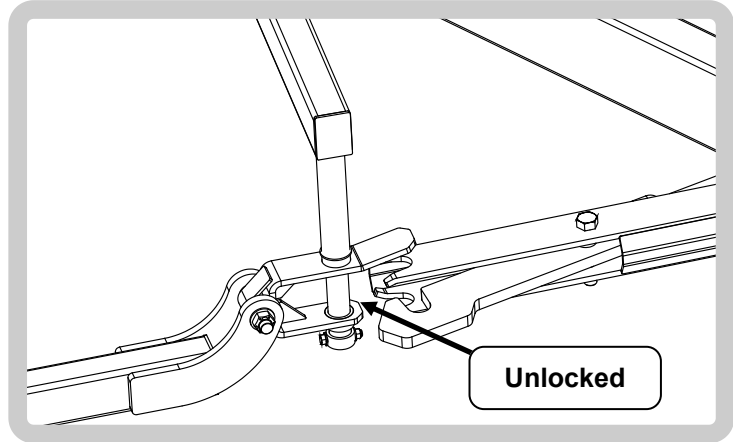

FIGURE 8

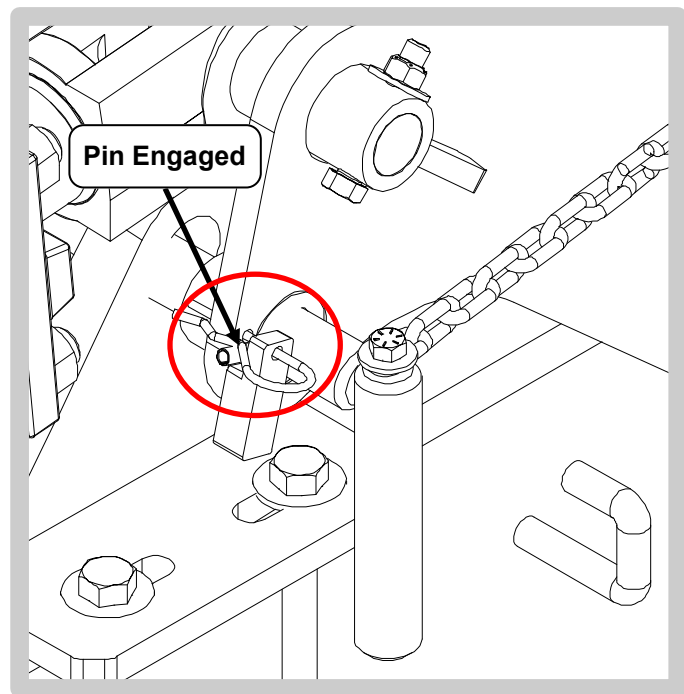

FIGURE 9

OPERATING INSTRUCTIONS

LEVELLING

1. Hitch unit up to tractor and unfold into field position on flat ground
2. Ensure the main lift cylinders are fully stoked outwards (measurement 60" eye to eye with full tine aggression)
3. Measure from the top of tubing on one of the lift arms to the ground (fig. 11).
4. Repeat measurement on the other end of the lift arm (fig. 11).
5. Adjust hitch clevis up or down accordingly until the measurements are within 1/4" of each other. (fig. 10).

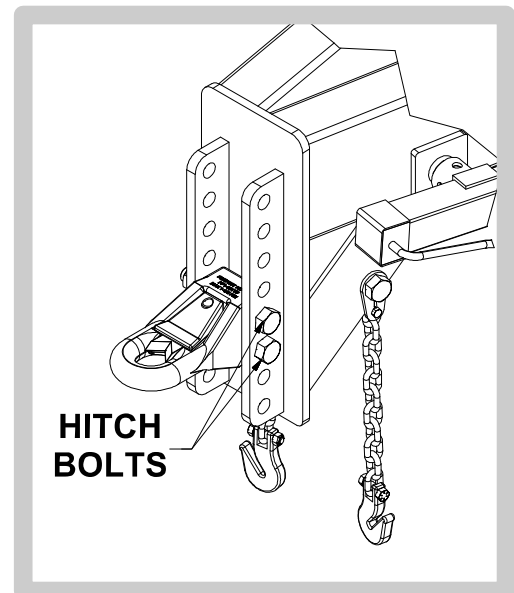

FIGURE 10

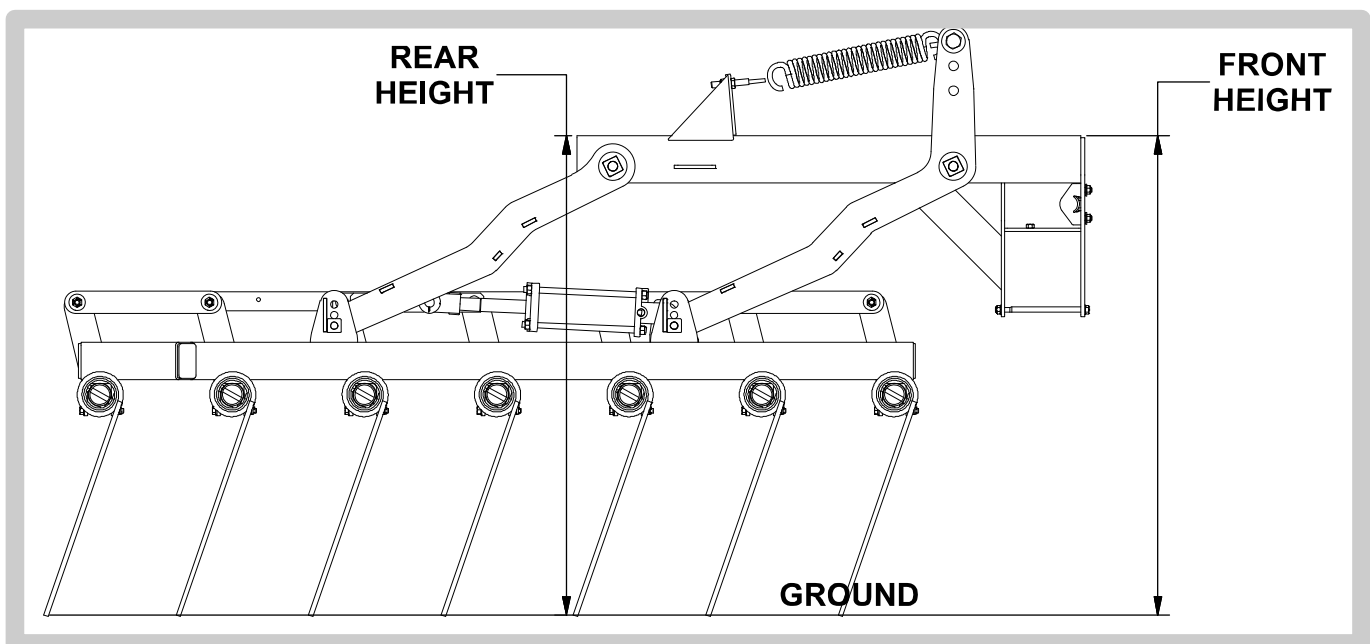

FIGURE 11

OPERATING INSTRUCTIONS

TINE SECTION ADJUSTMENT

- The Tine sections are fully adjustable based on your preferences and tine wear.
- Levelling:
 - **Before leveling the sections ensure the lift arms are properly leveled (Page 19)**
 - To level the section relocate the tine section pins in holes 1-3 (fig 12).
 - To bring the rear down, use rear #1 and front #3.
 - To bring the front down, use rear #3 and front #1.
 - The #2 setting can be used for less aggressive adjustments.
- Down pressure:
 - The down pressure can be adjusted by moving the spring position on the top of the lift arm, in holes A-C and D (fig 9).
 - For minimum downpressure, move the spring to hole A.
 - For maximum downpressure, move the spring to hole C.
 - Adjust D to tension the spring so that a piece of paper can slide between the coils.

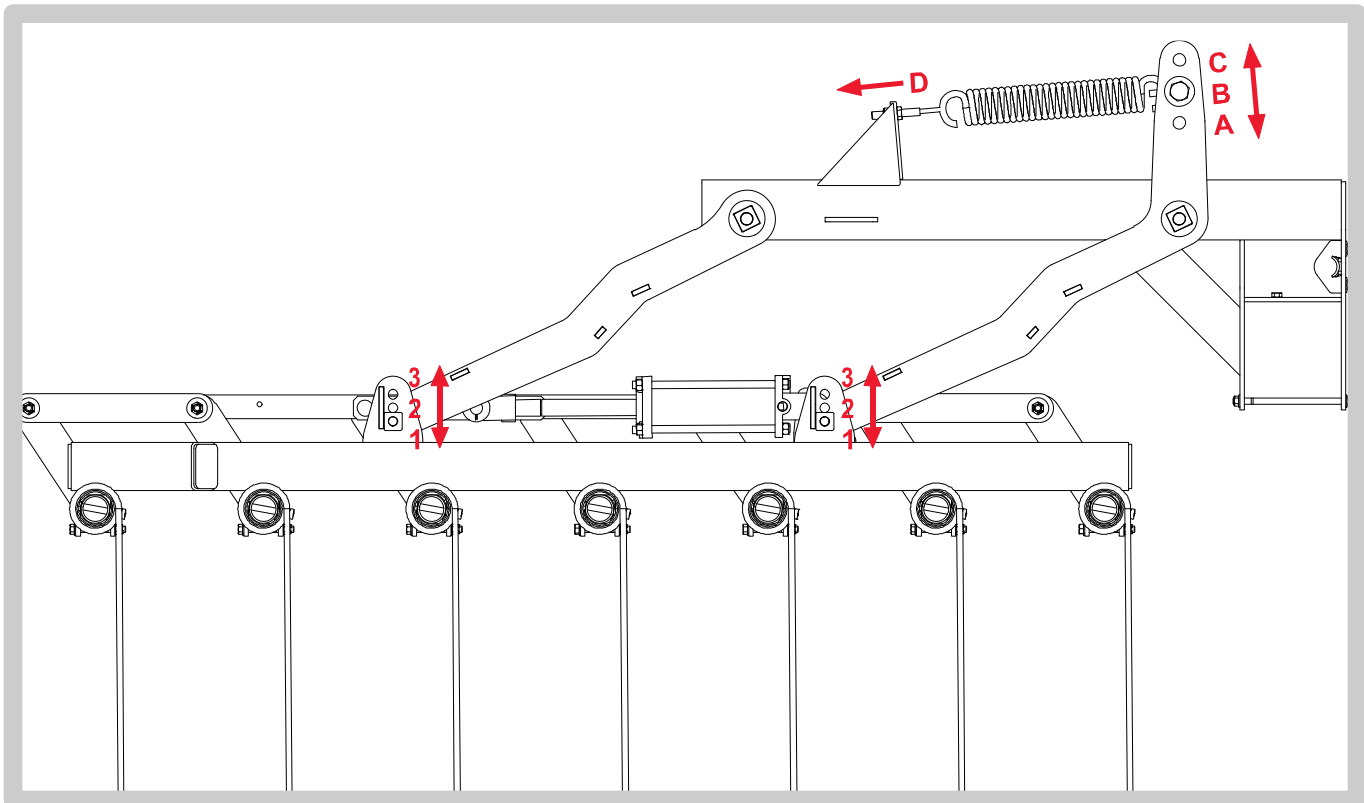

FIGURE 12

OPERATING INSTRUCTIONS



TRACTOR DISCONNECTING

1. Ensure that machine is in transport position
2. Put all lock pins into place
3. Block the A-frame tires, front and back, before disconnecting from the tractor
4. Apply lifting pressure at stubs on the wings with parking jack(s)
5. Pin the hitch parking jack in the downward position and crank to extend until the clevis lifts off the tractor hitch
6. Disconnect all hydraulic lines from the tractor
7. Pull out the tractor hitch pin

NOTE:

- **Ensure the jack is placed on firm ground prior to unhooking.**
- **Beware of sudden hitch up-ending due to negative hitch weight. Stay clear from the hitch when pulling ahead tractor as the hitch may rise suddenly.**

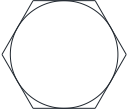
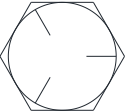
FASTENER GRADE CHART

Specification	Material	Size Range (inches)	Min. Proof Strength (psi)	Min. Tensile Strength (psi)	Min. Yield Strength (psi)	Grade Identification Marking
Grade 2	Low or Medium Carbon Steel	1/4 to 3/4 7/8 to 1-1/2	55,000 33,000	74,000 60,000	57,000 36,000	
Grade 5	Medium Carbon Steel: Quenched and Tempered	1/4 to 1 1-1/8 to 1-1/2	85,000 74,000	120,000 105,000	92,000 81,000	
Grade 8	Medium Carbon Alloy Steel: Quenched and Tempered	1/4 to 1-1/2	120,000	150,000	130,000	

FASTENER TORQUE CHART

Nominal Thread Size	Grade 2		Grade 5		Grade 8	
	Clamping Load	Tightening Torque	Clamping Load	Tightening Torque	Clamping Load	Tightening Torque
Coarse Thread						
1/4-20	1,300 lbs	65 in-lbs	2,000 lbs	100 in-lbs	2,850 lbs	143 in-lbs
5/16-18	2,150 lbs	134 in-lbs	3,350 lbs	210 in-lbs	4,700 lbs	305 in-lbs
3/8-16	3,200 lbs	20 ft-lbs	4,950 lbs	31 ft-lbs	6,950 lbs	44 ft-lbs
7/16-14	4,400 lbs	30 ft-lbs	6,800 lbs	50 ft-lbs	9,600 lbs	70 ft-lbs
1/2-13	5,850 lbs	49 ft-lbs	9,050 lbs	75 ft-lbs	12,800 lbs	107 ft-lbs
9/16-12	7,500 lbs	70 ft-lbs	11,600 lbs	109 ft-lbs	16,400 lbs	154 ft-lbs
5/8-11	9,300 lbs	97 ft-lbs	14,500 lbs	151 ft-lbs	20,300 lbs	211 ft-lbs
3/4-10	13,800 lbs	173 ft-lbs	21,300 lbs	266 ft-lbs	30,100 lbs	376 ft-lbs
7/8-9	11,425 lbs	166 ft-lbs	29,435 lbs	430 ft-lbs	41,550 lbs	606 ft-lbs
1-8	15,000 lbs	250 ft-lbs	38,600 lbs	640 ft-lbs	54,540 lbs	900 ft-lbs
Fine Thread						
1/4-28	1,500 lbs	75 in-lbs	2,300 lbs	115 in-lbs	3,250 lbs	163 in-lbs
5/16-24	2,400 lbs	150 in-lbs	3,700 lbs	230 in-lbs	5,200 lbs	325 in-lbs
3/8-24	3,600 lbs	23 ft-lbs	5,600 lbs	35 ft-lbs	7,900 lbs	50 ft-lbs
7/16-20	4,900 lbs	36 ft-lbs	7,550 lbs	55 ft-lbs	10,700 lbs	78 ft-lbs
1/2-20	6,600 lbs	55 ft-lbs	10,200 lbs	85 ft-lbs	14,400 lbs	120 ft-lbs
9/16-18	8,400 lbs	79 ft-lbs	13,000 lbs	112 ft-lbs	18,300 lbs	172 ft-lbs
5/8-18	10,600 lbs	110 ft-lbs	16,300 lbs	170 ft-lbs	23,000 lbs	240 ft-lbs
3/4-16	15,400 lbs	193 ft-lbs	23,800 lbs	298 ft-lbs	33,600 lbs	420 ft-lbs
7/8-14	12,610 lbs	184 ft-lbs	32,480 lbs	473 ft-lbs	45,855 lbs	668 ft-lbs

NOTES

SECTION 2

PARTS DETAILS – A-FRAME, HITCH

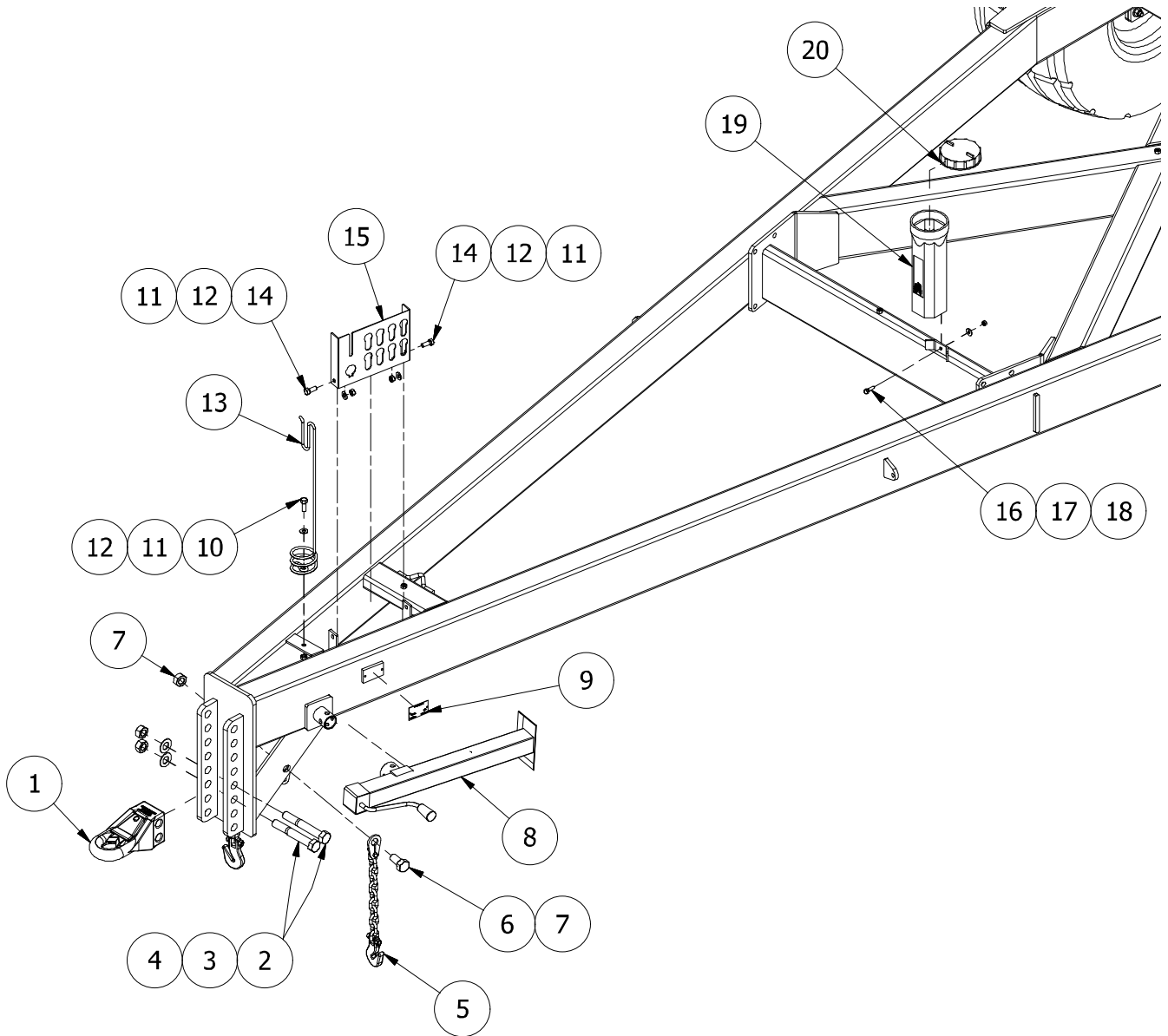

PARTS DETAILS – A-FRAME, HITCH

ITEM #	PART #	DESCRIPTION
1	423-0001	PP1-301VH PERFECT HITCH c/w PP1-301VH
2	526-1656	BOLT, 1-8 UNC - 7, GR.5, YELLOW ZINC PLATED
3	550-5316	WASHER, FLAT, 1" - SAE, GR.5, YELLOW ZINC PLATED
4	526-6109	NUT, STOVER LOCK, 1-8 UNC, GR.5, YELLOW ZINC PLATED
5	409-9050	SAFETY CHAIN 20,000LB, CLEVIS MOUNT, NEW STYLE
6	526-1616	BOLT, 1-8 UNC - 2, GR.5, YELLOW ZINC PLATED
7	526-6109	NUT, STOVER LOCK, 1-8 UNC, GR.5, YELLOW ZINC PLATED
8	420-0168	5000lb. 20" SQUARE SEWIND JACK 20.1"RL
9	060-0034	SERIAL PLATE
10	526-0812	BOLT, 1/2-13 UNC - 1.5, GR.5, YELLOW ZINC PLATED
11	550-5308	WASHER, FLAT, 1/2" - SAE, GR.5, YELLOW ZINC PLATED
12	526-6105	NUT, STOVER LOCK, 1/2-13 UNC, GR.5, YELLOW ZINC PLATED
13	407-0003	24" SHEPHERD HOOK HOSE STANDOFF
14	526-0810	BOLT, 1/2-13 UNC - 1.25, GR.5, YELLOW ZINC PLATED
15	835-1009	CHAIN AND TIP HOLDER 14-1/4 X 8
16	526-0610	BOLT, 3/8-16 UNC - 1.25, GR.5, YELLOW ZINC PLATED
17	550-5206	WASHER, FLAT, 3/8" - SAE, GR.5, YELLOW ZINC PLATED
18	526-6103	NUT, STOVER LOCK, 3/8-16 UNC, GR.5, YELLOW ZINC PLATED
19	426-0001	MANUAL STORAGE TUBE
20	426-0002	MANUAL STORAGE TUBE CAP

PARTS DETAILS – A-FRAME, AXLE

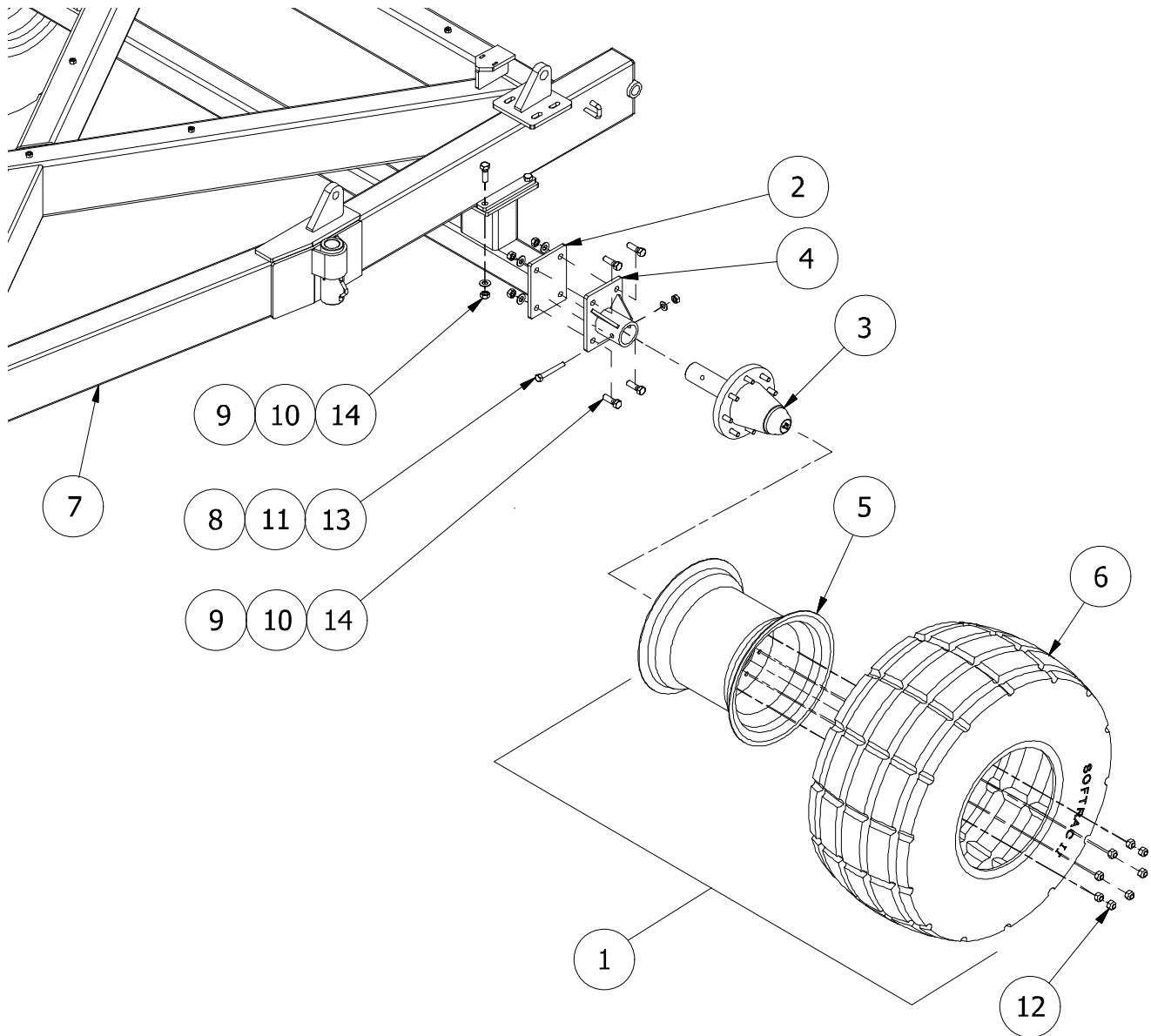

PARTS DETAILS – A-FRAME, AXLE

ITEM #	PART #	DESCRIPTION
1	020-0105	16.5 - 16.1 8 BOLT TIRE AND WHEEL ASS'Y
2	120-1117	8200 UNIVERSAL CENTRE AXLE
3	120-1246	812 HUB & SPINDLE ASSEMBLY
4	120-1230	CENTRE AXLE STUB ASSEMBLY
5	204-5585	W14C x 16.1" - 8 HOLE WHEEL, 3/8" OFFSET
6	205-1192	16.5 X 16.1 6 PLY TIRE
7	105-0363	8100 A-FRAME WELDMENT, W TIE BAR
8	526-0932	BOLT, 9/16-12 UNC - 4, GR.5, YELLOW ZINC PLATED
9	526-1016	BOLT, 5/8-11 UNC - 2, GR.5, YELLOW ZINC PLATED
10	526-6106	NUT, STOVER LOCK, 5/8-11 UNC, GR.5, YELLOW ZINC PLATED
11	526-6112	NUT, STOVER LOCK, 9/16-12 UNC, GR.5, YELLOW ZINC PLATED
12	543-5563	9/16 WHEEL NUT, NF, Gr.5, PLTD.
13	550-5309	WASHER, FLAT, 9/16" - SAE, GR.5, YELLOW ZINC PLATED
14	550-5310	WASHER, FLAT, 5/8" - SAE, GR.5, YELLOW ZINC PLATED

PARTS DETAILS – A-FRAME, CENTER BAR

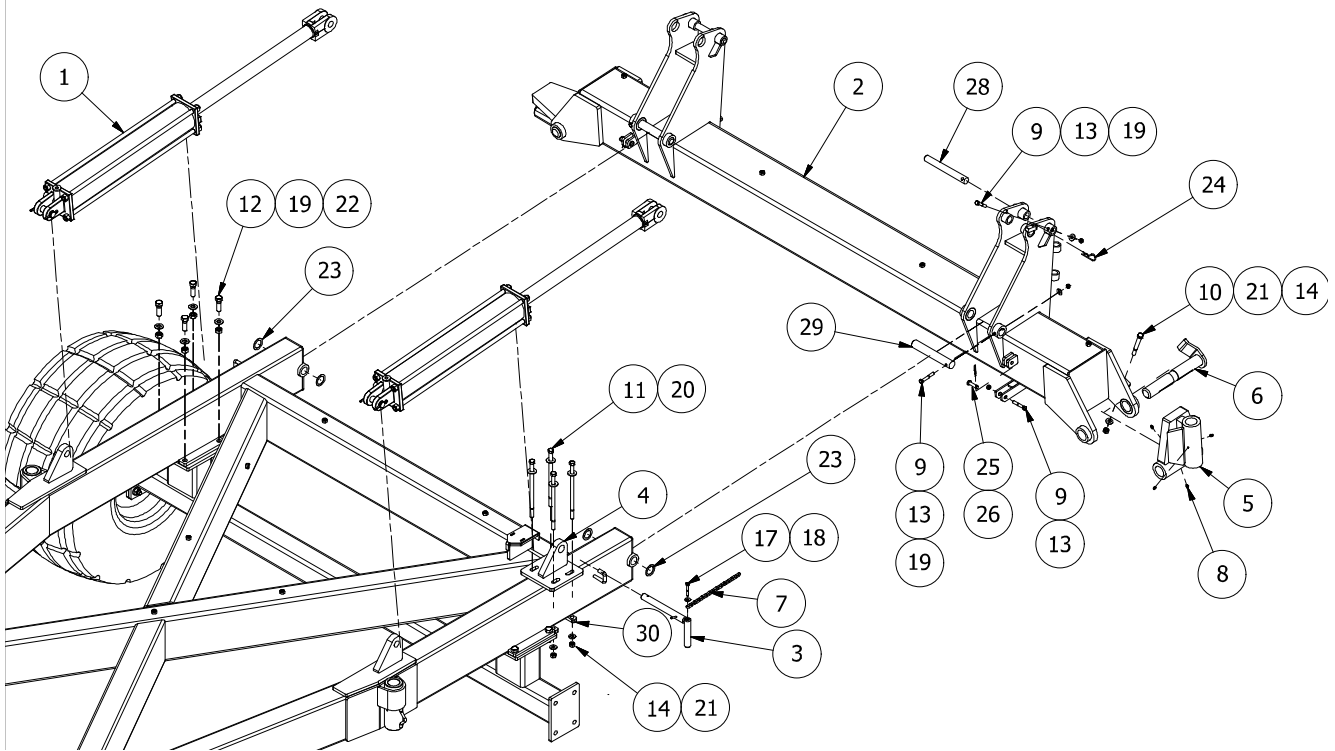

PARTS DETAILS – A-FRAME, CENTER BAR

ITEM #	PART #	DESCRIPTION
1	030-5985	TIE ROD CYLINDER, 4" BORE X 24" STROKE, 1.5" ROD, 36" RL
2	105-1246	CENTRE BAR WELDMENT (REVISED ANGLE)
3	105-1328	HYD. VALVE LOCK PIN WELDMENT (HOLLOW)
4	112-0509	HYD. LOCK LUG WELDMENT
5	113-0031	1-3/4 X 1-3/4 KNUCKLE
6	123-3204	1-3/4 X 11-1/4 KNUCKLE LOCK PIN
7	409-9057	HYD. LOCK PIN CHAIN
8	419-0004	GREASE ZERK, 1/4"NF - STRAIGHT
9	526-0620	BOLT, 3/8-16 UNC - 2.25, GR.5, YELLOW ZINC PLATED
10	526-0836	BOLT, 1/2-13 UNC - 4.5, GR.5, YELLOW ZINC PLATED
11	526-0880	BOLT, 1/2-13 UNC - 10, GR.5, YELLOW ZINC PLATED
12	526-1016	BOLT, 5/8-11 UNC - 2, GR.5, YELLOW ZINC PLATED
13	526-6103	NUT, STOVER LOCK, 3/8-16 UNC, GR.5, YELLOW ZINC PLATED
14	526-6105	NUT, STOVER LOCK, 1/2-13 UNC, GR.5, YELLOW ZINC PLATED
15	526-6106	NUT, STOVER LOCK, 5/8-11 UNC, GR.5, YELLOW ZINC PLATED
17	530-0516	BOLT, 5/16-18 UNC - 2, GR.8, YELLOW ZINC PLATED
19	550-5206	WASHER, FLAT, 3/8" - USS, GR.5, YELLOW ZINC PLATED
20	550-5208	WASHER, FLAT, 1/2" - USS, GR.5, YELLOW ZINC PLATED
21	550-5308	WASHER, FLAT, 1/2" - SAE, GR.5, YELLOW ZINC PLATED
22	550-5310	WASHER, FLAT, 5/8" - SAE, GR.5, YELLOW ZINC PLATED
23	554-1065	WASHER, FLAT, 1 1/4 - Narrow, GR.5, YELLOW ZINC PLATED
24	558-2057	#9 HITCH PIN CLIP, PLTD.
25	558-2059	3/32 x 2-5/16 #7 HITCH PIN CLIP
26	560-0808	1/2 X 1-3/4 CLEVIS PIN (JUMBO)
28	807-2804	1 X 8-5/8 LIFT CYLINDER PIN
29	807-3205	CENTRE BAR PIVOT PIN
30	815-1008	LOCK LUG TIE PLATE

PARTS DETAILS – A-FRAME, AUTOFOLD

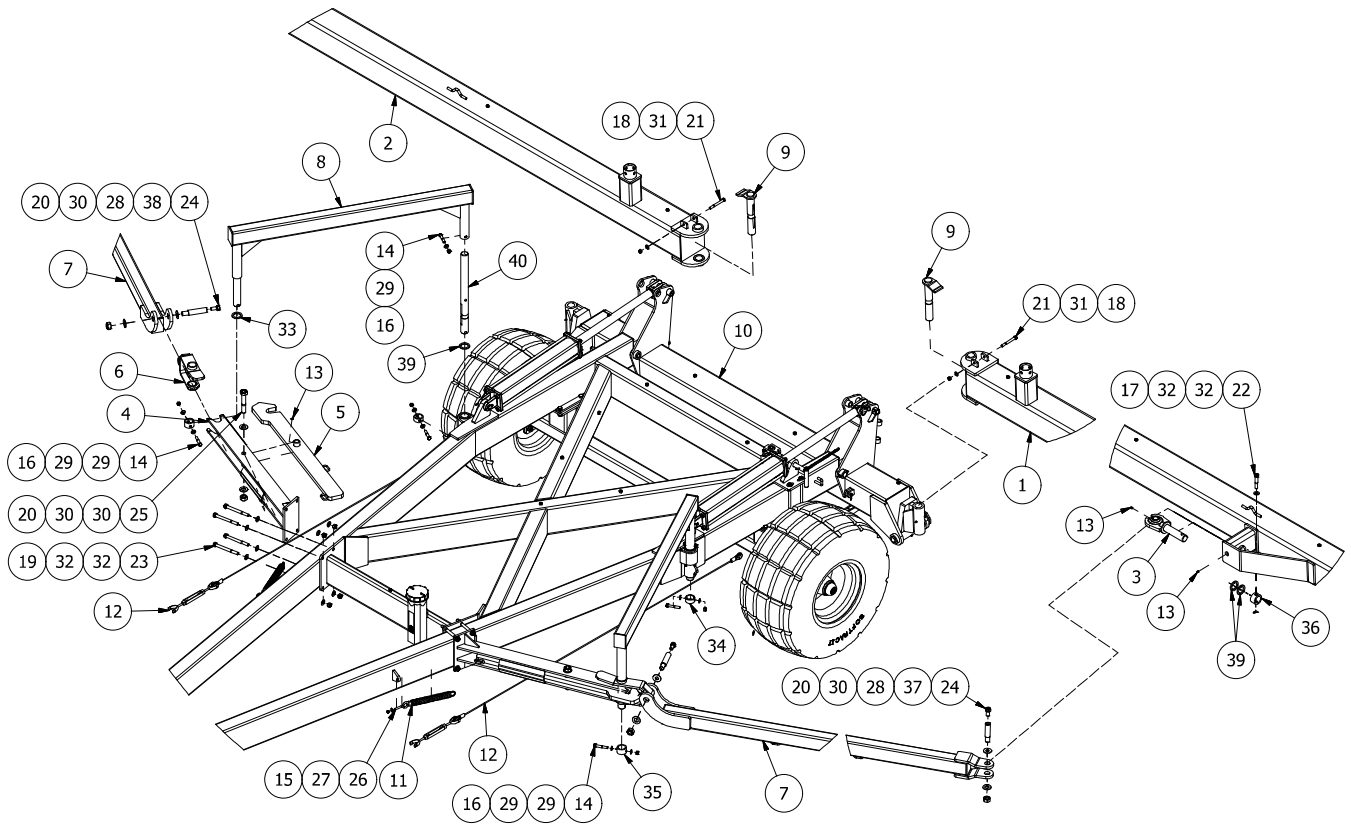

PARTS DETAILS – A-FRAME, AUTOFOLD

ITEM #	PART #	DESCRIPTION
1	Varies	WING - SEE PAGE 16
2	Varies	WING - SEE PAGE 16
3	105-1259	DRAFT ARM PULL LUG PIN, EXTENDED (1-1/4")
4	Varies	LOCK BOX - SEE PAGE 16
5	Varies	LOCK ARM - SEE PAGE 16
6	112-0507	DRAFT ARM CLEVIS WELDMENT, (1-5/16")
7	Varies	DRAFT ARM - SEE PAGE 16
8	112-0606	SWING ARM WELDMENT - BOLT IN SHAFT
9	123-3204	1-3/4 X 11-1/4 KNUCKLE LOCK PIN
10	105-1246	CENTRE BAR WELDMENT (REVISED ANGLE)
11	403-0267	1-1/2" X 12-1/2" AUTO FOLD SPRING
12	410-0321	1/4" X 97" AUTO FOLD CABLE c/w 3/8" X 6" TURN BUCKLE
13	419-0004	GREASE ZERK, 1/4"NF - STRAIGHT
14	526-0824	BOLT, 1/2-13 UNC - 3, GR.5, YELLOW ZINC PLATED
15	526-6103	NUT, STOVER LOCK, 3/8-16 UNC, GR.5, YELLOW ZINC PLATED
16	526-6105	NUT, STOVER LOCK, 1/2-13 UNC, GR.5, YELLOW ZINC PLATED
17	526-6106	NUT, STOVER LOCK, 5/8-11 UNC, GR.5, YELLOW ZINC PLATED
18	526-7308	1/2 STOVER LOCK NUT, NC, GR.8, PLTD.
19	526-7310	NUT, STOVER LOCK, 5/8-11 UNC, GR.8, YELLOW ZINC PLATED
20	526-7316	NUT, STOVER LOCK, 1-8 UNC, GR.8, YELLOW ZINC PLATED
21	530-0772	BOLT, 1/2-13 UNC - 4.5, GR.8, YELLOW ZINC PLATED
22	530-1000	BOLT, 5/8-11 UNC - 3.5, GR.8, YELLOW ZINC PLATED
23	530-1006	BOLT, 5/8-11 UNC - 6.5, GR.8, YELLOW ZINC PLATED
24	530-1246	BOLT, 3/4-10 UNC - 1.5, GR.8, YELLOW ZINC PLATED
25	530-1644	BOLT, 1-8 UNC - 5.5, GR.8, YELLOW ZINC PLATED
26	546-0199	3/8 X 4 EYE BOLT, NC, Gr.5, PLTD.
27	550-5206	WASHER, FLAT, 3/8 - Regular - Type B, GR.5, YELLOW ZINC PLATED
28	550-5212	WASHER, FLAT, 3/4 - Regular - Type B, GR.5, YELLOW ZINC PLATED
29	550-5308	WASHER, FLAT, 1/2" - SAE, GR.5, YELLOW ZINC PLATED
30	550-5316	WASHER, FLAT, 1" - SAE, GR.5, YELLOW ZINC PLATED
31	550-5613	WASHER, FLAT, 1/2 SAE, GR.8, YELLOW ZINC PLATED
32	550-5617	WASHER, FLAT, 5/8 SAE, GR.8, YELLOW ZINC PLATED
33	554-5401	1-3/4 ID X 10 Ga. MACHINE WASHER, PLTD.
34	805-6018	2 1/4 OD x .240W CDSM - 1
35	805-6021	2-1/4 OD x .240W CDSM - 1-3/8
36	805-7608	2-1/2 OD X .365W CDSM - 1-3/8
37	827-0077	PIN, 1-1/4" OD, CR 1045, 5", END THREADED 1"UNC
38	827-0078	PIN, 1-1/4" OD, CR 1045, 6-1/8", END THREADED 1"UNC
39	805-6005	PULL LUG SPACER, 1/4"
40	807-3654	SWING ARM SHAFT, BOLT IN, 1045

PARTS DETAILS – WINGS, STEERING

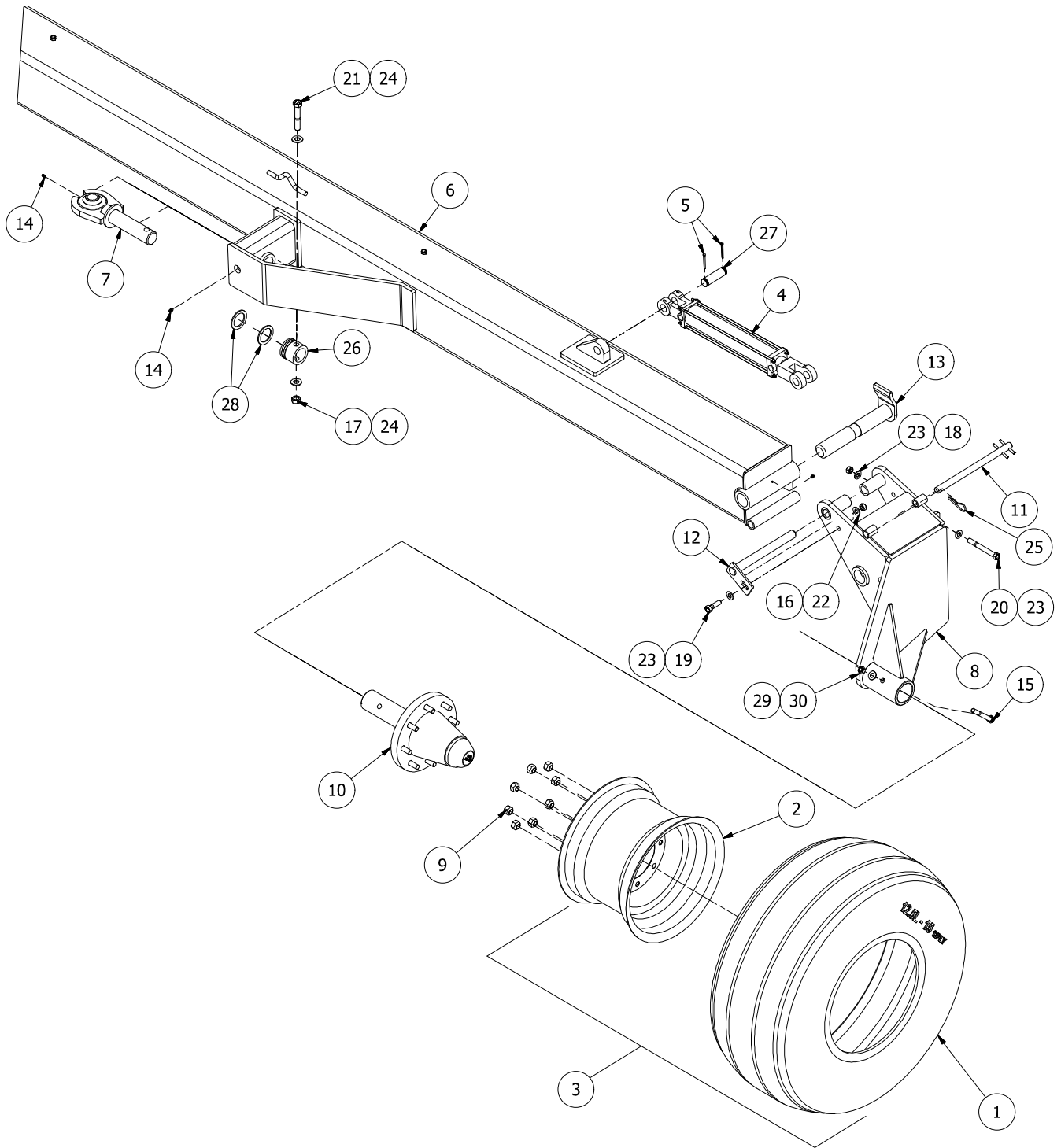

PARTS DETAILS – WINGS, STEERING

ITEM #	PART #	DESCRIPTION
1*	205-1193	12.5 X 15 TIRE - 8 PLY TIRE
1*	205-1180	11 X 15 TIRE - 8 PLY TIRE
2*	204-5586	WHEEL RIM 15x10x10 8 BOLT
2*	204-5565	WHEEL RIM 15x8x6 6 BOLT
3*	020-0142	12.5L15 15x10x10 8 BOLT TIRE AND WHEEL ASS'Y
3*	020-0144	11L15 15x8x6 6 BOLT TIRE AND WHEEL ASS'Y
4	030-5979	2 X 12 HYDRAULIC CYLINDER, 22.25" RL
5	556-0906	3/16 X 1-3/4 COTTER PIN PLTD
6	Varies	WING, SEE PAGE 16
7	105-1259	DRAFT ARM PULL LUG PIN, EXTENDED (1-1/4")
8*	120-1238	LEFT WING AXLE WELDMENT
8*	120-1239	RIGHT WING AXLE WELDMENT
9	543-5563	9/16 WHEEL NUT, NF, GR.5, PLTD.
10	Varies	HUB & SPINDLE SEE PAGE 24-25
11	123-1807	3/4" x 11-1/2" WHEEL TEE LOCK PIN
12	123-2222	WING AXLE CYLINDER LOCK PIN WLD.
13	123-3204	1-3/4 X 11-1/4 KNUCKLE LOCK PIN
14	419-0004	GREASE ZERK, 1/4"NF - STRAIGHT
15	526-0932	BOLT, 9/16-12 UNC - 4, GR.5, YELLOW ZINC PLATED
16	526-6105	NUT, STOVER LOCK, 1/2-13 UNC, GR.5, YELLOW ZINC PLATED
17	526-6106	NUT, STOVER LOCK, 5/8-11 UNC, GR.5, YELLOW ZINC PLATED
18	526-7308	1/2 STOVER LOCK NUT, NC, GR.8, PLTD.
19	530-0742	BOLT, 1/2-13 UNC - 1.75, GR.8, YELLOW ZINC PLATED
20	530-0772	BOLT, 1/2-13 UNC - 4.5, GR.8, YELLOW ZINC PLATED
21	530-1000	BOLT, 5/8-11 UNC - 3.5, GR.8, YELLOW ZINC PLATED
22	550-5308	WASHER, FLAT, 1/2" - SAE, GR.5, YELLOW ZINC PLATED
23	550-5613	WASHER, FLAT, 1/2 SAE, GR.8, YELLOW ZINC PLATED
24	550-5617	WASHER, FLAT, 5/8 SAE, GR.8, YELLOW ZINC PLATED
25	558-2057	#9 HITCH PIN CLIP, PLTD.
26	805-7608	2-1/2 OD X .365W CDSM - 1-3/8
27	807-2809	1 X 3-3/8 CYLINDER PIN, PLTD.
28	839-1961	PULL LUG SPACER, 1/4"
29	550-5309	WASHER, FLAT, 9/16" - SAE, GR.5, YELLOW ZINC PLATED
30	526-6112	NUT, STOVER LOCK, 9/16-12 UNC, GR.5, YELLOW ZINC PLATED

PARTS DETAILS – CENTER, LIFT ARMS

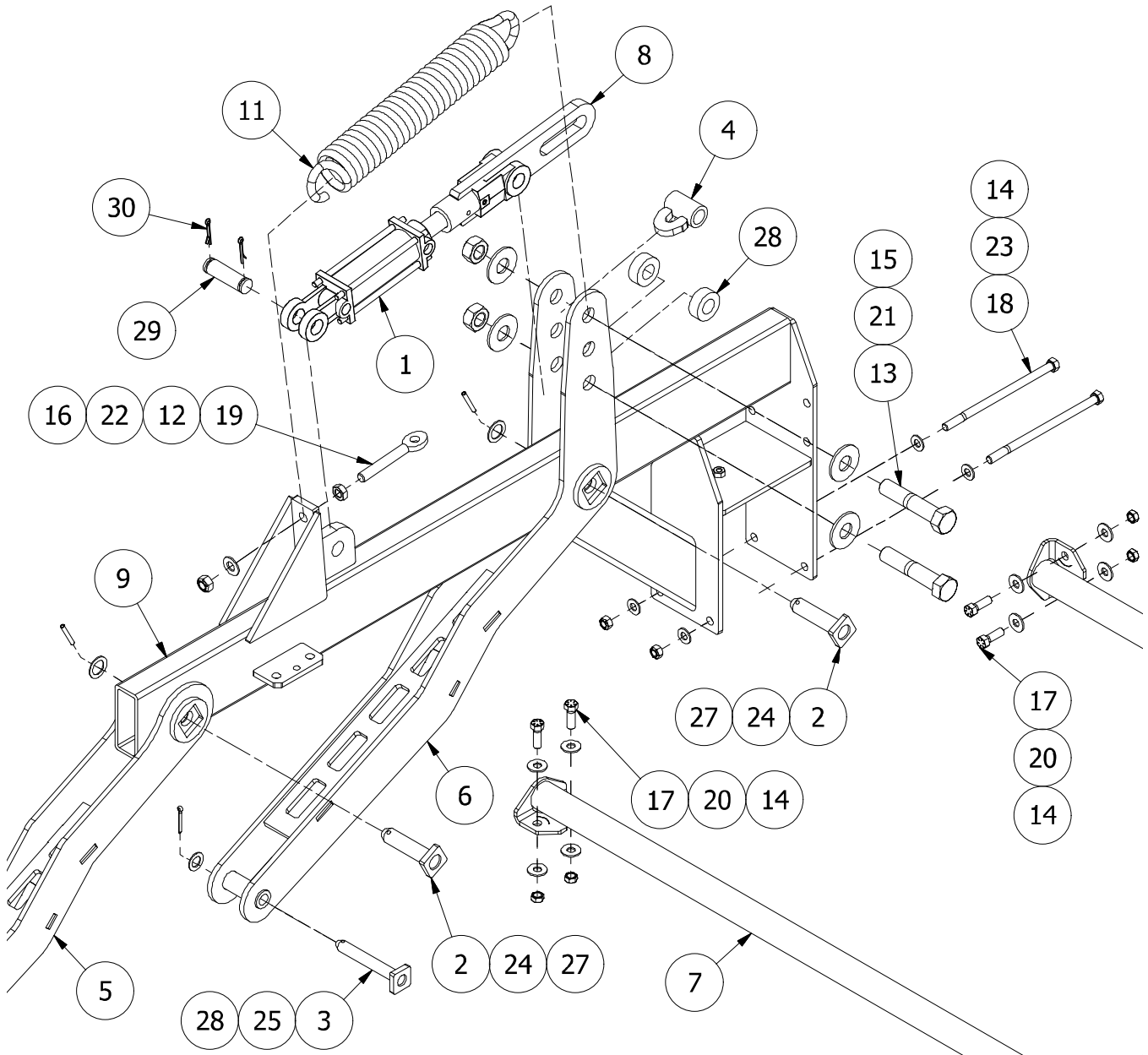

PARTS DETAILS – CENTER, LIFT ARMS

ITEM #	PART #	DESCRIPTION
1	030-5904	2 X 4 CYL - 112 BODY
2	105-1162	HARROW PIN, 1 X 3 3/8 USABLE LG
3	105-1163	HARROW PIN, 3/4 X 4 3/4 USABLE LG
4	105-1164	LUG, EXT SPRING KIT
5	105-1165	LINK ARM, FLOATING
6	105-1169	LINK ARM, DRIVEN
7	105-1183	CROSS BAR, LONG
8	105-1250	HELPER CYLINDER CLEVIS WELDMENT
9	105-1257	LIFT ARM, CENTER
11	403-0282	SPRING, EXTENSION, 3" OD, 0.531" WIRE, 19-1/2" LG
12	525-6110	NUT, JAM, HEX, 5/8-11 UNC, GR.5, YELLOW ZINC PLATED
13	526-1640	BOLT, 1-8 UNC - 5, GR.5, YELLOW ZINC PLATED
14	526-6105	1/2 STOVER LOCK NUT, NC, GR.5, PLTD.
15	526-6109	NUT, STOVER LOCK, 1-8 UNC, GR.5, YELLOW ZINC PLATED
16	526-7310	NUT, STOVER LOCK, 5/8-11 UNC, GR.8, YELLOW ZINC PLATED
17	530-0740	BOLT, 1/2-13 UNC - 1.5, GR.8, YELLOW ZINC PLATED
18	530-0760	BOLT, 1/2-13 UNC - 9.5, GR.8, YELLOW ZINC PLATED
19	546-0219	BOLT, SPADE, 5/8-11 NC, GR. 5 - 4" LG
20	550-5208	WASHER, FLAT, 1/2 - USS, GR.5, YELLOW ZINC PLATED
21	550-5216	WASHER, FLAT, 1" - USS, GR.5, YELLOW ZINC PLATED
22	550-5310	WASHER, FLAT, 5/8" - SAE, GR.5, YELLOW ZINC PLATED
23	550-5613	WASHER, FLAT, 1/2 SAE, GR.8, YELLOW ZINC PLATED
24	554-5405	MACHINERY BUSHING, 1 ID X 14 GA, PLTD.
25	554-5414	MACHINERY BUSHING, 3/4 ID X 14 GA, PLTD.
26	556-0612	COTTER PIN - 3/16" X 1" PLAIN
27	556-1621	1/4 X 2 ROLL PIN, PLTD.
28	839-1955	SPACER WASHER
29	807-2809	1" x 3-3/8" Cylinder Pin, Pltd.
30	556-0906	3/16" x 1-3/4" Cotter Pin, Pltd.

PARTS DETAILS – WINGS, LIFT ARMS

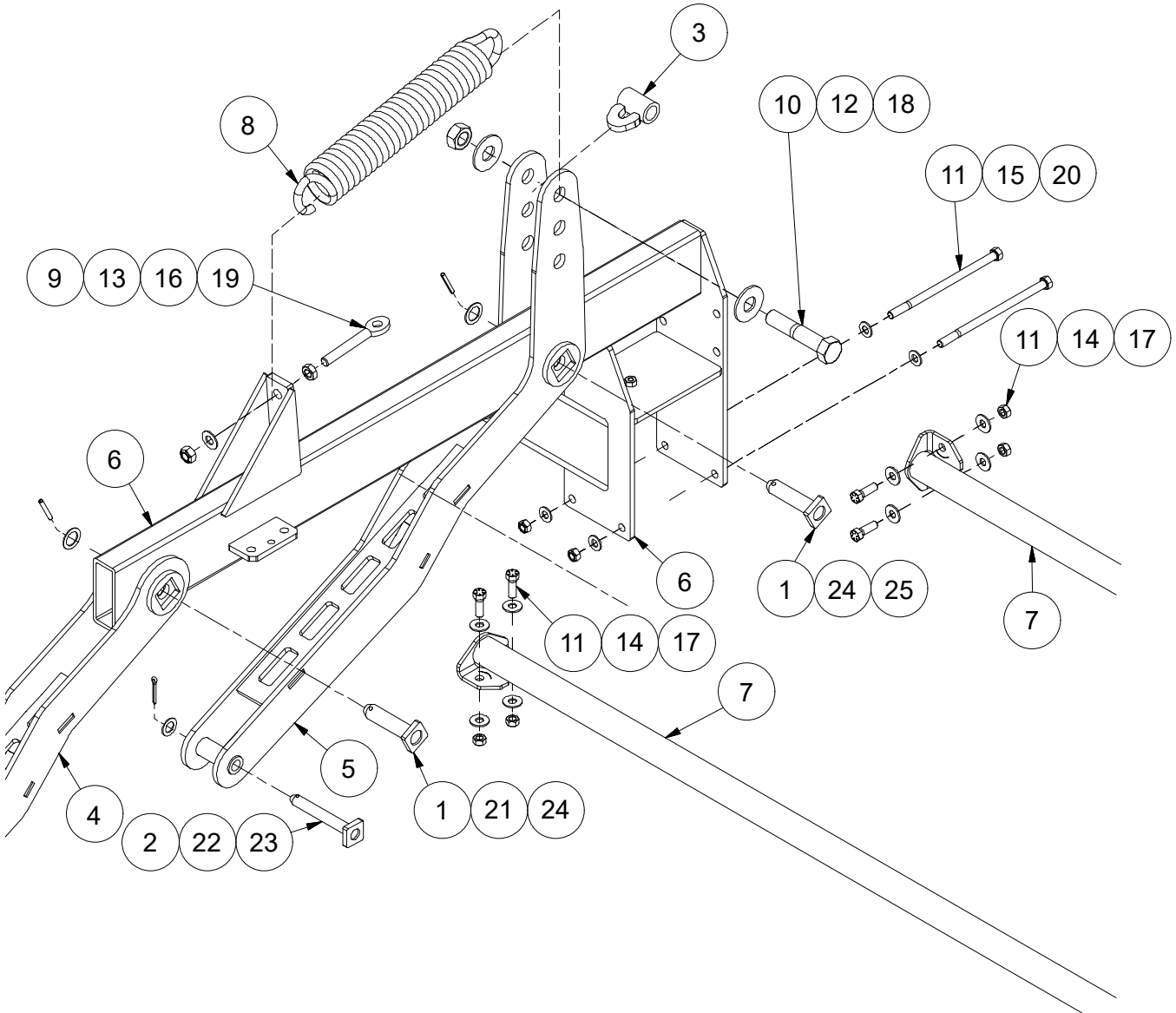

PARTS DETAILS – WINGS, LIFT ARMS

ITEM #	PART #	DESCRIPTION
1	105-1162	HARROW PIN, 1 X 3 3/8 USABLE LG
2	105-1163	HARROW PIN, 3/4 X 4 3/4 USABLE LG
3	105-1164	LUG, EXT SPRING KIT
4	105-1165	LINK ARM, FLOATING
5	105-1169	LINK ARM, DRIVEN
6	105-1182	LIFT ARM, WING
7*	105-1183	CROSS BAR, LONG
7*	105-1258	CROSS BAR, SHORT
8	403-0282	SPRING, EXTENSION, 3" OD, 0.531" WIRE, 19-1/2" LG
9	525-6110	NUT, JAM, HEX, 5/8-11 UNC, GR.5, YELLOW ZINC PLATED
10	526-1640	BOLT, 1-8 UNC - 5, GR.5, YELLOW ZINC PLATED
11	526-6105	NUT, STOVER LOCK, 1/2-13 UNC, GR.5, YELLOW ZINC PLATED
12	526-6109	NUT, STOVER LOCK, 1-8 UNC, GR.5, YELLOW ZINC PLATED
13	526-7310	NUT, STOVER LOCK, 5/8-11 UNC, GR.8, YELLOW ZINC PLATED
14	530-0740	BOLT, 1/2-13 UNC - 1.5, GR.8, YELLOW ZINC PLATED
15	530-0760	BOLT, 1/2-13 UNC - 9.5, GR.8, YELLOW ZINC PLATED
16	546-0219	BOLT, SPADE, 5/8-11 NC, GR. 5 - 4" LG
17	550-5208	WASHER, FLAT, 1/2 - USS, GR.5, YELLOW ZINC PLATED
18	550-5216	WASHER, FLAT, 1" - USS, GR.5, YELLOW ZINC PLATED
19	550-5310	WASHER, FLAT, 5/8" - SAE, GR.5, YELLOW ZINC PLATED
20	550-5613	WASHER, FLAT, 1/2 SAE, GR.8, YELLOW ZINC PLATED
21	554-5405	MACHINERY BUSHING, 1 ID X 14 GA, PLTD.
22	554-5414	MACHINERY BUSHING, 3/4 ID X 14 GA, PLTD.
23	556-0612	COTTER PIN - 3/16" X 1" PLAIN
24	556-1621	1/4 X 2 ROLL PIN, PLTD.

PARTS DETAILS – CENTER, LIFT ARMS PROFILED

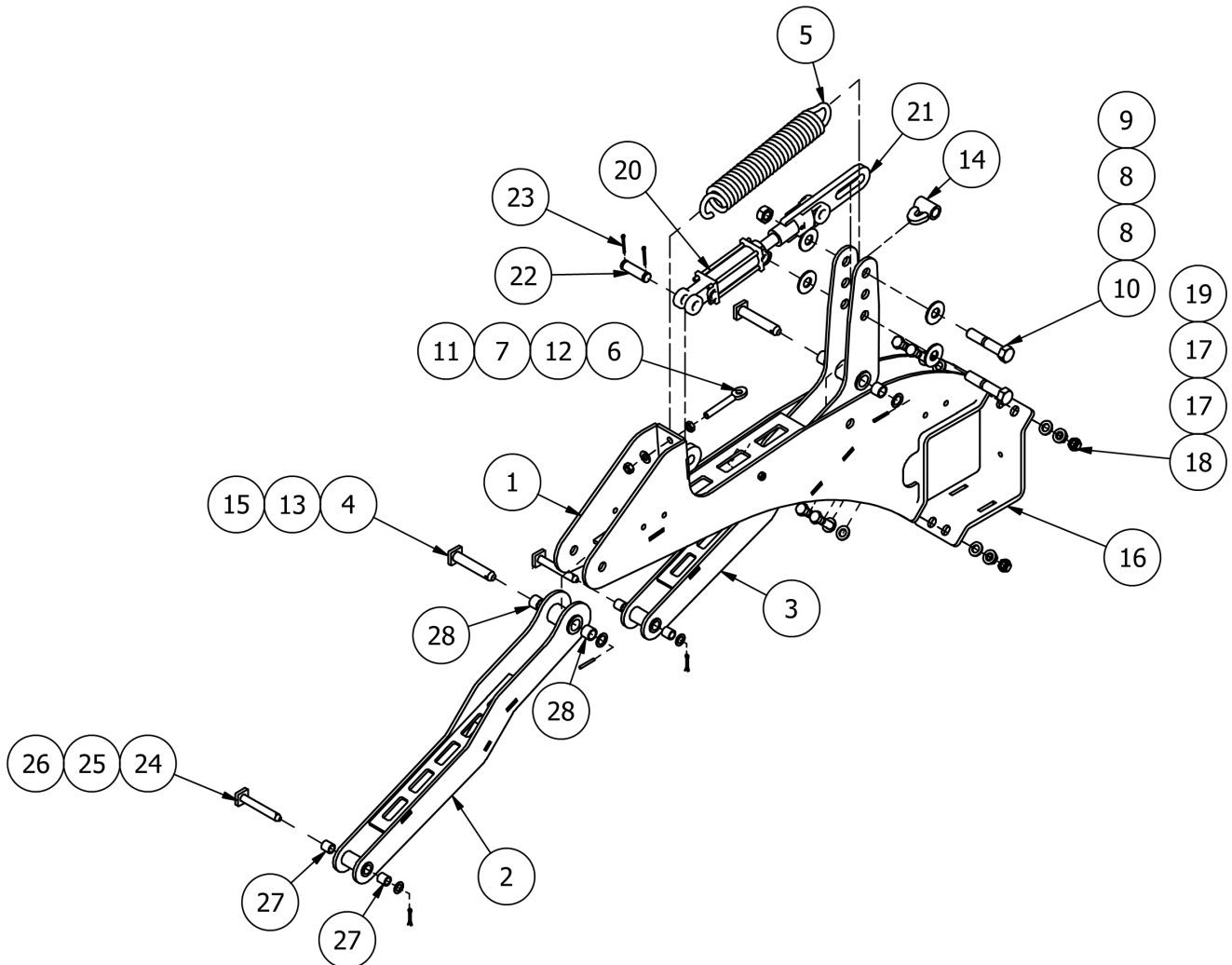

PARTS DETAILS – CENTER, LIFT ARMS PROFILED

ITEM #	PART #	DESCRIPTION
1	105-1344	LIFT ARM, PROFILED, EXTENDED
2	160-0728	LINK, IDLER W/ BUSHINGS
3	160-0729	LINK, DRIVEN W/ BUSHINGS
4	105-1343	HARROW PIN, $\phi 1 \times 4 \frac{5}{8}$ USABLE LG
5	403-0275	SPRING, EXTENSION, 3" OD, 0.531" WIRE, 19-1/2" LG
6	546-0219	BOLT, SPADE, 5/8-11 NC, GR. 5 - 4" LG
7	550-5310	WASHER, FLAT, 5/8" - SAE, GR.5, YELLOW ZINC PLATED
8	550-5216	WASHER, FLAT, 1" - USS, GR.5, YELLOW ZINC PLATED
9	526-6109	NUT, STOVER LOCK, 1-8 UNC, GR.5, YELLOW ZINC PLATED
10	526-1640	BOLT, 1-8 UNC - 5, GR.5, YELLOW ZINC PLATED
11	526-7310	NUT, STOVER LOCK, 5/8-11 UNC, GR.8, YELLOW ZINC PLATED
12	525-6110	NUT, JAM, HEX, INCH, GRADE 5, YELLOW ZINC PLATED
13	554-5405	MACHINERY BUSHING, 1 ID X 14 GA, PLTD.
14	105-1164	LUG, EXT SPRING KIT
15	556-1621	1/4 X 2 ROLL PIN, PLTD.
16	839-2099	LIFT ARM V CLAMP
17	550-5312	WASHER, FLAT, 3/4" - SAE, GR.5, YELLOW ZINC PLATED
18	526-6107	NUT, STOVER LOCK, 3/4-10 UNC, GR.5, YELLOW ZINC PLATED
19	526-1222	BOLT, 3/4-10 UNC - 2.75, GR.5, YELLOW ZINC PLATED
20	030-5904	2 X 4 CYL - 112 BODY
21	105-1250	HELPER CYLINDER CLEVIS WELDMENT
22	807-2809	1 X 3-3/8 CYLINDER PIN, PLTD.
23	556-0906	3/16 X 1-3/4 COTTER PIN PLTD
24	105-1163	HARROW PIN, $\phi 3/4 \times 4 \frac{3}{4}$ USABLE LG
25	554-5414	MACHINERY BUSHING, 3/4 ID X 14 GA, PLTD.
26	556-0612	COTTER PIN, 3/16 x 1 1/2, ZINC PLATED
27	610-0021	BUSHING, 0.75 x 1 x 1
28	610-0014	BUSHING, 1 x 1.26 x 1

PARTS DETAILS – WINGS, LIFT ARMS PROFILED

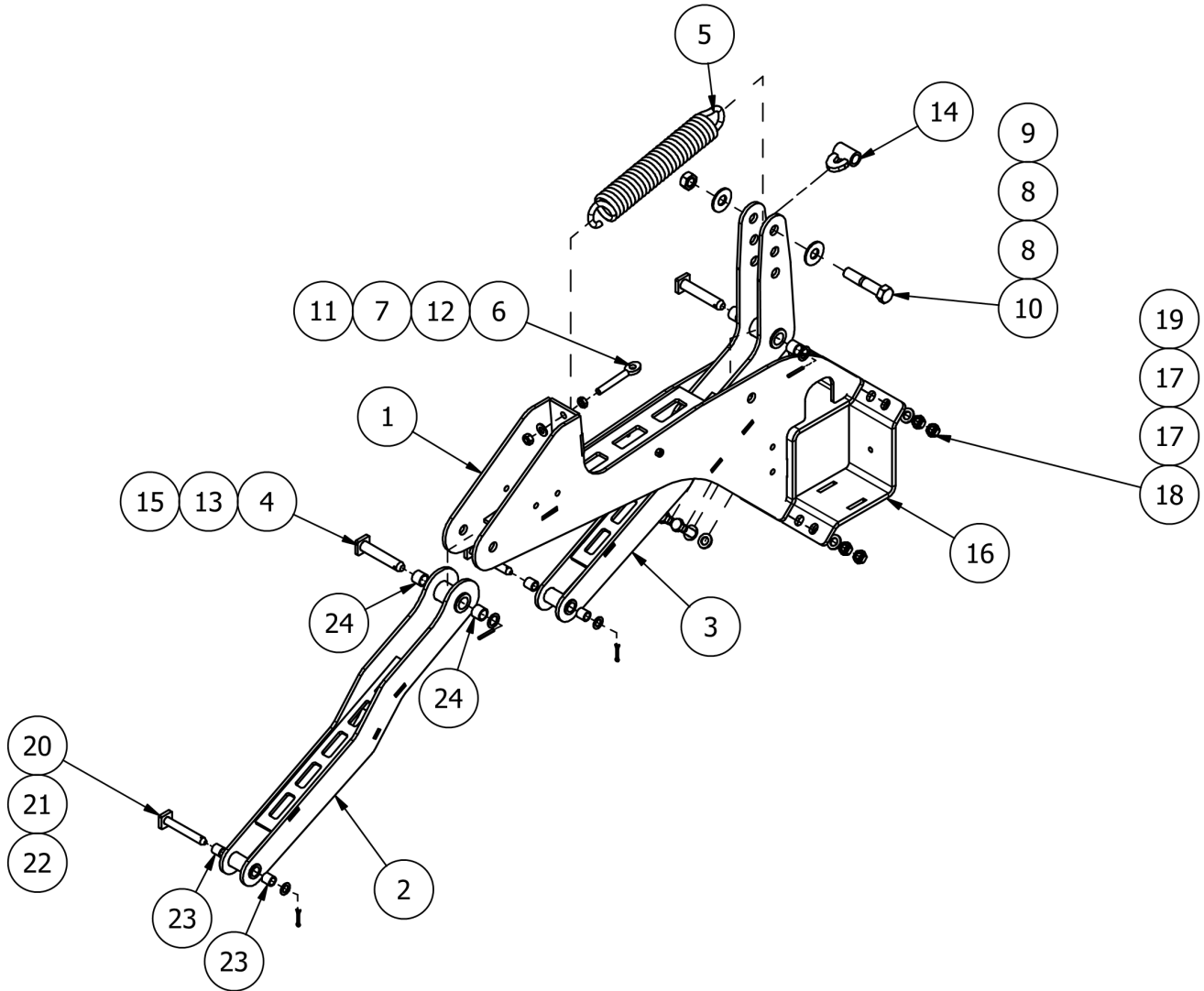

PARTS DETAILS – WINGS, LIFT ARMS PROFILED

ITEM #	PART #	DESCRIPTION
1	105-1342	LIFT ARM, PROFILED
2	160-0728	LINK, IDLER W/ BUSHINGS
3	160-0729	LINK, DRIVEN W/ BUSHINGS
4	105-1343	HARROW PIN, $\phi 1 \times 4 \frac{5}{8}$ USABLE LG
5	403-0275	SPRING, EXTENSION, 3" OD, 0.531" WIRE, 19-1/2" LG
6	546-0219	BOLT, SPADE, 5/8-11 NC, GR. 5 - 4" LG
7	550-5310	WASHER, FLAT, 5/8" - SAE, GR.5, YELLOW ZINC PLATED
8	550-5216	WASHER, FLAT, 1" - USS, GR.5, YELLOW ZINC PLATED
9	526-6109	NUT, STOVER LOCK, 1-8 UNC, GR.5, YELLOW ZINC PLATED
10	526-1640	BOLT, 1-8 UNC - 5, GR.5, YELLOW ZINC PLATED
11	526-7310	NUT, STOVER LOCK, 5/8-11 UNC, GR.8, YELLOW ZINC PLATED
12	525-6110	NUT, JAM, 5/8-11 UNC, GR.5, YELLOW ZINC PLATED
13	554-5405	MACHINERY BUSHING, 1 ID X 14 GA, PLTD.
14	105-1164	LUG, EXT SPRING KIT
15	556-1621	1/4 X 2 ROLL PIN, PLTD.
16	839-2099	LIFT ARM V CLAMP
17	550-5312	WASHER, FLAT, 3/4" - SAE, GR.5, YELLOW ZINC PLATED
18	526-6107	NUT, STOVER LOCK, 3/4-10 UNC, GR.5, YELLOW ZINC PLATED
19	526-1222	BOLT, 3/4-10 UNC - 2.75, GR.5, YELLOW ZINC PLATED
20	105-1163	HARROW PIN, $\phi 3/4 \times 4 \frac{3}{4}$ USABLE LG
21	554-5414	MACHINERY BUSHING, 3/4 ID X 14 GA, PLTD.
22	556-0612	COTTER PIN, 3/16 x 1 1/2, ZINC PLATED
23	610-0021	BUSHING, 0.75 x 1 x 1
24	610-0014	BUSHING, 1 x 1.26 x 1

PARTS DETAILS – WINGS, MEASUREMENTS

UNIT	SECTION 1		SECTION 2		SECTION 3		SECTION 4		WING LENGTH
HH-8245	26-3/4"	63-1/2"	122-13/16"	183-3/16"					204"
HH-8255	39-5/16"	94-11/16"	173-13/16"	229-3/16"					258"
HH-8268	43-15/16"	99-5/16"	171-9/16"	189-15/16"	262-15/16"	317-11/16"			340"
HH-8278	39-5/16"	94-11/16"	173-13/16"	229-3/16"	308-5/16"	363-11/16"			388"
HH-8290	30-7/8"	49-1/4"	120-13/16"	176-3/16"	255-5/16"	310-11/16"	389-13/16"	445-3/16"	462"
HH-8240	26-3/4"	63-1/2"	122-13/16"	183-3/16"					204"
HH-8250	39-5/16"	94-11/16"	173-13/16"	229-3/16"					258"
HH-8262	43-15/16"	99-5/16"	171-9/16"	189-15/16"	262-15/16"	317-11/16"			340"
HH-8273	39-5/16"	94-11/16"	173-13/16"	229-3/16"	308-5/16"	363-11/16"			388"
MH-7258	48	103-3/8"	190-3/8"	241-3/4"					264"
MH-7272	48-7/8"	104-1/4"	174-1/8"	199-5/16"	269-1/4"	324-5/8"			348"
MH-7282	47-11/16"	103-1/16"	188-9/16"	243-15/16"	329-7/16"	384-13/16"			406"
RH-9245	4-5/8"	36-5/16"	100-5/8"						162"
RH-9260	4-5/8"	36-5/16"	100-5/8"	132-5/16"	196-5/8"				258"
RH-9275	4-5/8"	36-5/16"	100-5/8"		196-5/8"	228-5/16"	292-5/8"		348"

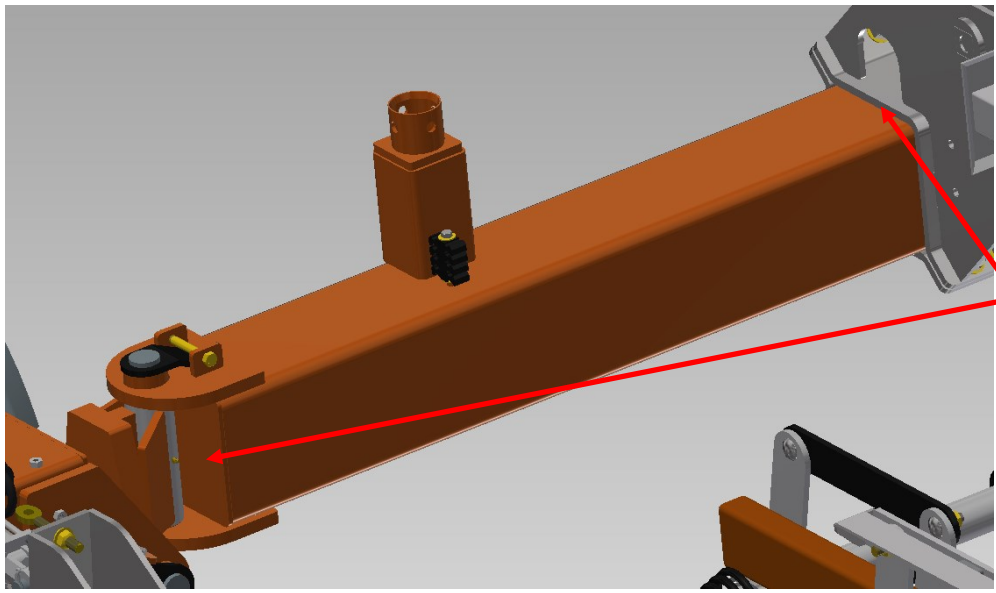

ALL DIMENSIONS ARE MEASURED FROM THE WING END CAP TO THE CLOSEST FACE OF THE RELATED LIFT ARM CLAMP

PARTS DETAILS – WINGS, MAJOR COMPONENTS

NOTE: Detail view on page 8

UNIT	PART #	DESCRIPTION	DIMENSION
45'	105-1302	WING, 8200, LEFT, 40'/45'	204" (17' - 0")
	105-1303	WING, 8200, RIGHT, 40'/45'	
	112-0603	DRAFT ARM, 40'/45', 45'	142-3/4"
	112-0115	LOCK BOX, 45', 55', 45', 60', 58'	46-1/2" (Long edge)
	112-0234	LOCK ARM, 45', 55', 45', 60', 58'	43-5/16" (Long edge)
55'	105-1304	WING, 8200, LEFT, 50'/55"	258" (21' - 6")
	105-1305	WING, 8200, RIGHT, 50'/55"	
	112-0604	DRAFT ARM, 58', 60'	185-3/8"
	112-0115	LOCK BOX, 45', 55', 45', 60', 58'	46-1/2" (Long edge)
	112-0234	LOCK ARM, 45', 55', 45', 60', 58'	43-5/16" (Long edge)
68'	105-1306	WING, 8200, LEFT, 62'/68'	340" (28' - 4")
	105-1307	WING, 8200, RIGHT, 62'/68'	
	105-1151	DRAFT ARM, 62', 68', 75'	253-3/4"
	112-0324	LOCK BOX, 68', 78', 72', 75'	41" (Long edge)
	112-0323	LOCK ARM, 68', 78', 72', 75'	39-9/16" (Long edge)
78'	105-1308	WING, 8200, LEFT, 73'/78'	388" (32' - 4")
	105-1309	WING, 8200, RIGHT, 73'/78'	
	105-1152	DRAFT ARM, 73'/78'	282-9/16"
	112-0324	LOCK BOX, 68', 78', 72', 75'	41" (Long edge)
	112-0323	LOCK ARM, 68', 78', 72', 75'	39-9/16" (Long edge)

PARTS DETAILS – SECTIONS, 11', FRAME

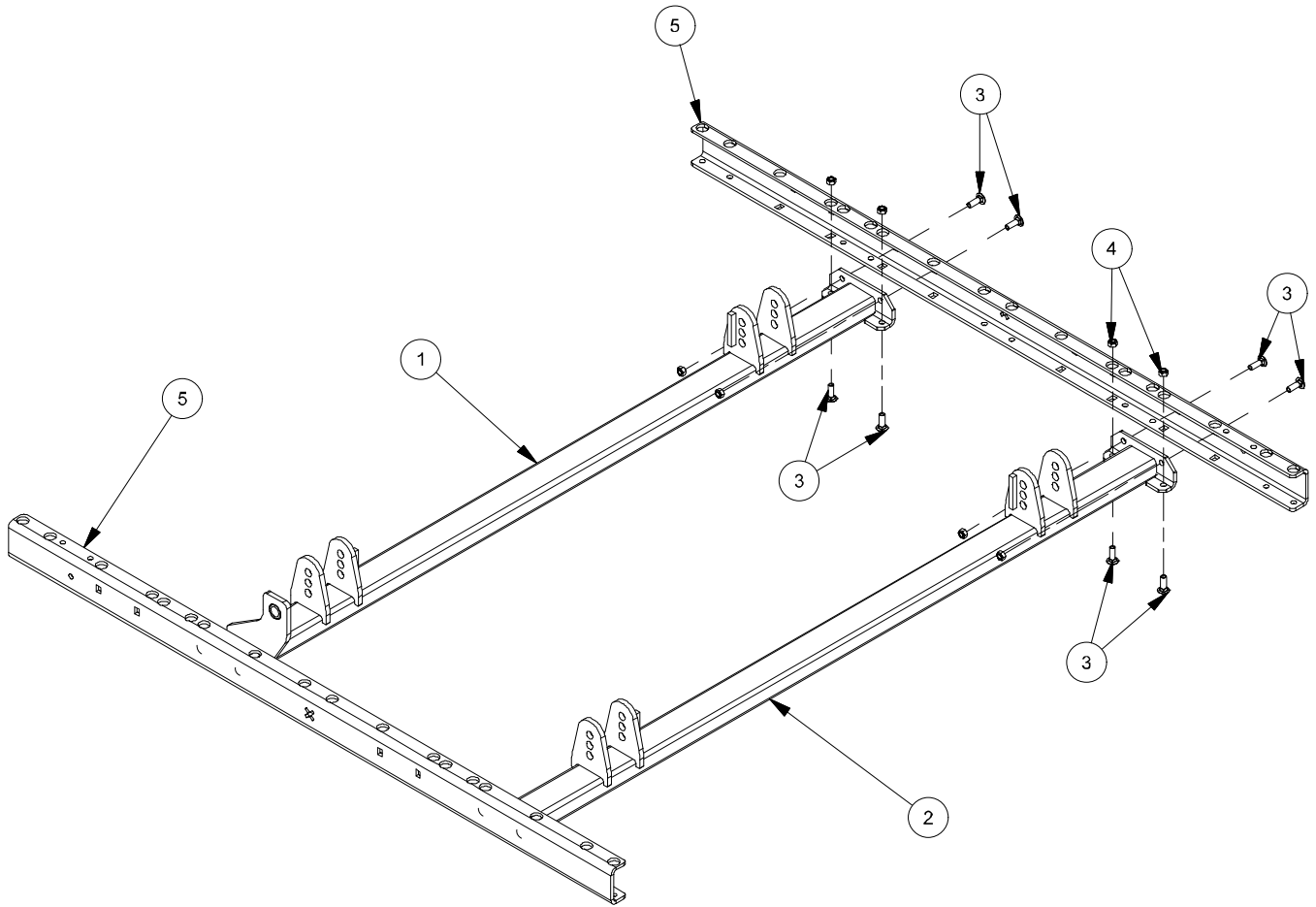

ITEM #	PART #	DESCRIPTION
	160-0582	11' JUMBO HARROW FRAME ASSEMBLY
1	105-1070	11' FRONT CROSS MEMBER, BOLT ON
2	105-1071	11' FRONT CROSS MEMBER, BOLT ON
3	526-6105	NUT, STOVER LOCK, 1/2-13 UNC, GR.5, YELLOW ZINC PLATED
4	542-0812	CARRIAGE BOLT, 1/2-13 UNC - 1.5, GR.5, YELLOW ZINC PLATED
5	839-1268	HARROW FRAME RAIL, UNIVERSAL

PARTS DETAILS – SECTIONS, 11'

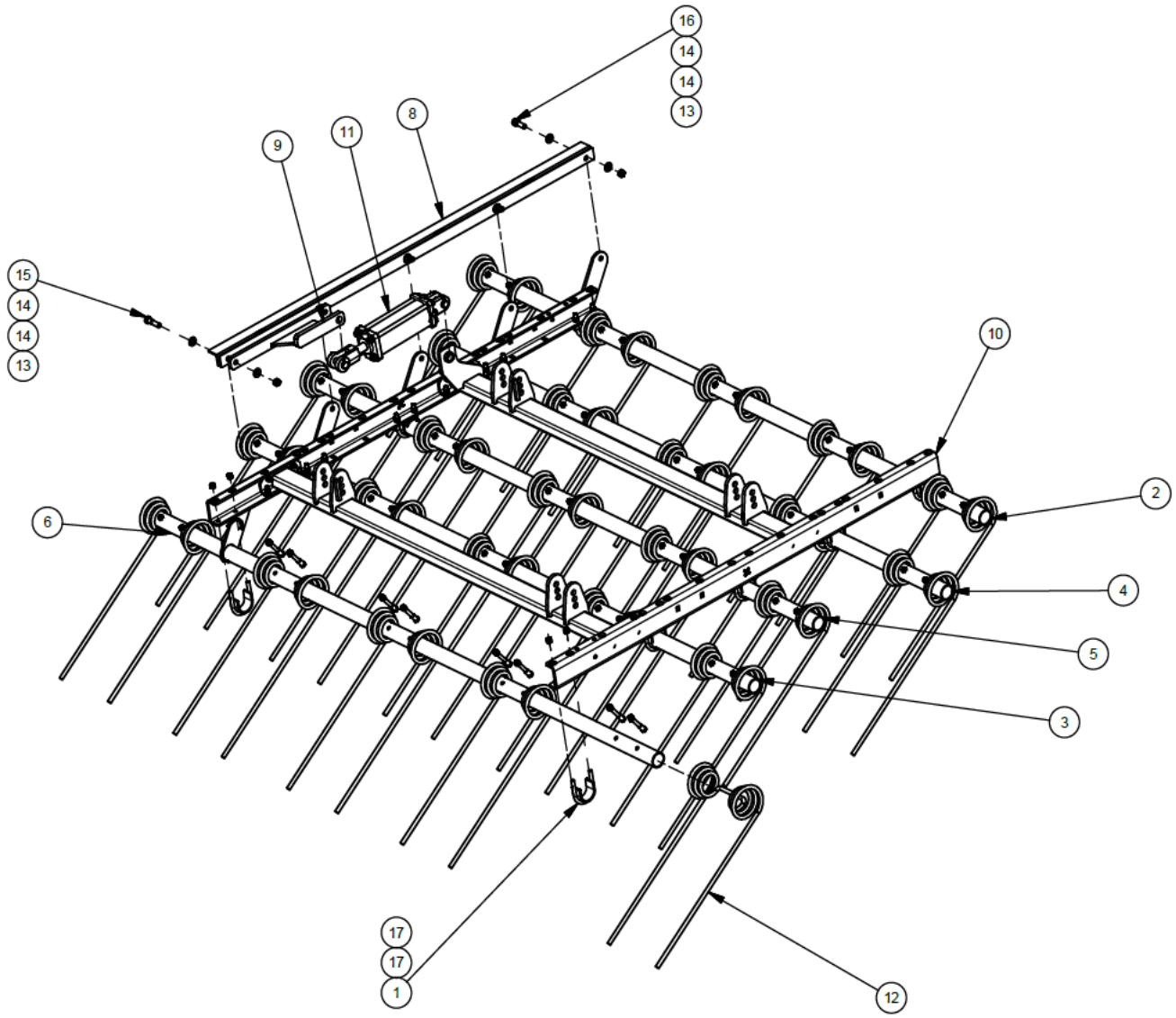

PARTS DETAILS – SECTIONS, 11'

ITEM #	PART #	DESCRIPTION
	160-0584	HARROW SECTION, 5-BAR, 11'
1	105-0085	HARROW PIPE U-BOLT CLAMP WLD. 1/2" x 3-1/2"
2	105-1333	5 BAR, PIPE 1, 11' UNIVERSAL PIPE
3	105-1336	5 BAR, PIPE 4, 11' UNIVERSAL PIPE
4	105-1334	5 BAR, PIPE 2, 11' UNIVERSAL PIPE
5	105-1335	5 BAR, PIPE 3, 11' UNIVERSAL PIPE
6	105-1337	5 BAR, PIPE 5, 11' UNIVERSAL PIPE
7	545-0015	1/2 X 3-3/4 HIGH HEAD HARROW BOLT
8	116-8002r1	HARROW ADJUSTING LINKAGE
9	112-0132	11' TINE ADJUSTMENT WELDMENT
10	160-0582	11' Jumbo Harrow Frame Assembly
11	030-5738	3-1/2 X 8 CYL, 1-1/4 SHAFT, 3/4" ORB 90 DEG P-P
12*	404-0028	9/16" X 28" HARROW TINE
12*	404-0035	9/16" X 28" HARROW TINE, W/ WEAR GUARD
12*	404-0030	5/8" X 28" HARROW TINE
12*	404-0037	5/8" X 28" HARROW TINE, W/ WEAR GUARD
13	526-6106	NUT, STOVER LOCK, 5/8-11 UNC, GR.5, YELLOW ZINC PLATED
14	550-5310	WASHER, FLAT, 5/8" - SAE, GR.5, YELLOW ZINC PLATED
15	526-1020	BOLT, 5/8-11 UNC - 2.5, GR.5, YELLOW ZINC PLATED
16	526-1016	BOLT, 5/8-11 UNC - 2, GR.5, YELLOW ZINC PLATED
17	526-7008	NYLOCK LOCK-NUT, HEX, INCH, GRADE 5, YELLOW ZINC PLATED

PARTS DETAILS – WELDED SECTIONS, 11'

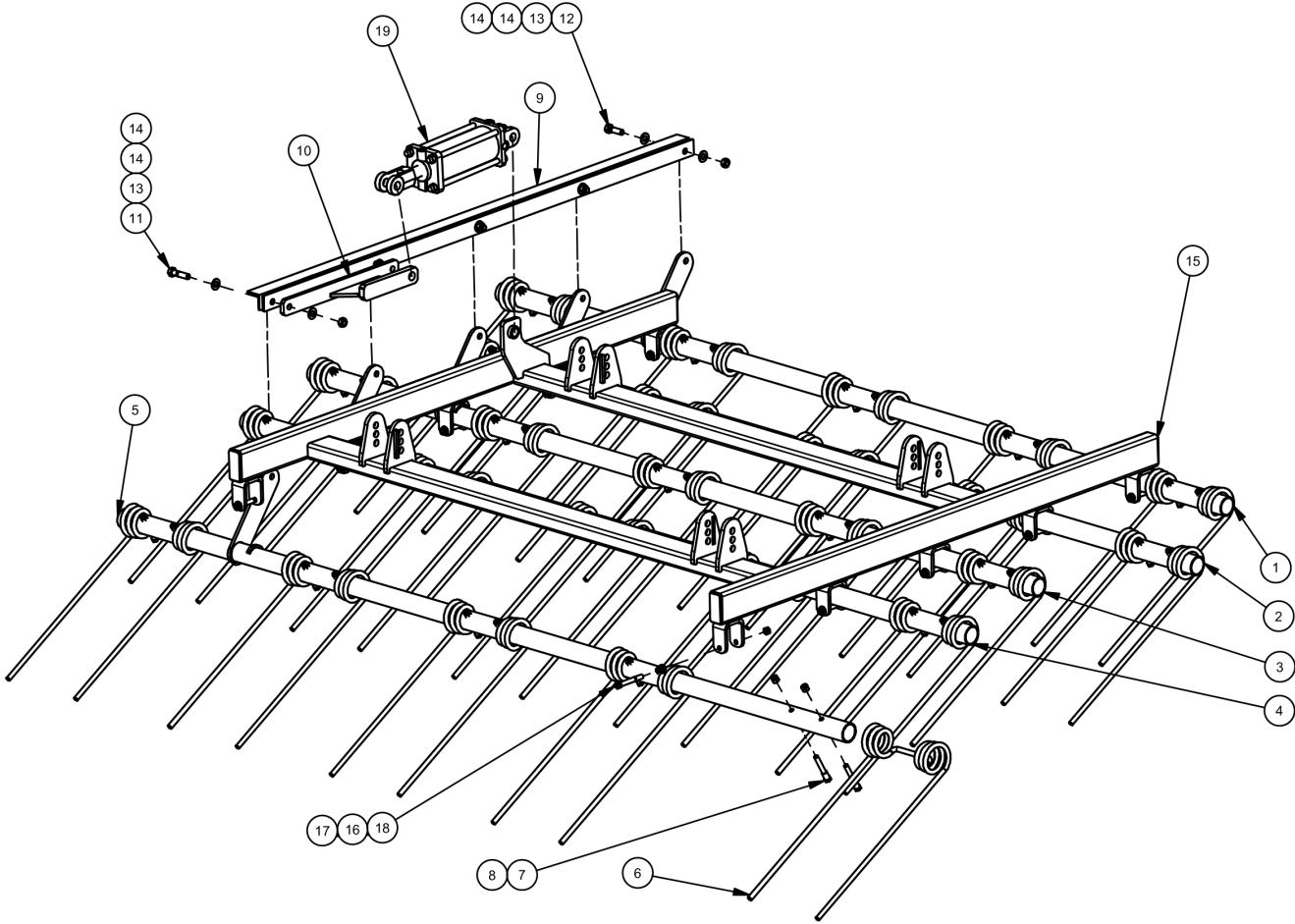

PARTS DETAILS – WELDED SECTIONS, 11'

ITEM #	PART #	DESCRIPTION
	160-0584	HARROW SECTION, 5-BAR, 11'
1	105-1333	5 BAR, PIPE 1, 11' UNIVERSAL PIPE
2	105-1334	5 BAR, PIPE 2, 11' UNIVERSAL PIPE
3	105-1335	5 BAR, PIPE 3, 11' UNIVERSAL PIPE
4	105-1336	5 BAR, PIPE 4, 11' UNIVERSAL PIPE
5	105-1337	5 BAR, PIPE 5, 11' UNIVERSAL PIPE
6	404-0010	2-3/8 ID X 26 HARROW TINE
7	545-0015	1/2 X 3-3/4 HIGH HEAD HARROW BOLT
8	526-6208	NUT, NYLOC, 1/2-13 UNC, GR.5, YELLOW ZINC PLATED
9	116-8002r1	HARROW ADJUSTING LINKAGE
10	112-0132	11' TINE ADJUSTMENT WELDMENT
11	530-1018	BOLT, 5/8-11 UNC - 2.5, GR.8, YELLOW ZINC PLATED
12	530-1002	BOLT, 5/8-11 UNC - 2, GR.8, YELLOW ZINC PLATED
13	526-7310	NUT, STOVER LOCK, 5/8-11 UNC, GR.8, YELLOW ZINC PLATED
14	550-5617	WASHER, FLAT, 5/8 SAE, GR.8, YELLOW ZINC PLATED
15	105-1072	5 BAR 11' JUMBO HAROW FRAME WELDED
16	550-5308	WASHER, FLAT, 1/2" - SAE, GR.5, YELLOW ZINC PLATED
17	526-6105	NUT, STOVER LOCK, 1/2-13 UNC, GR.5, YELLOW ZINC PLATED
18	530-0754	BOLT, 1/2-13 UNC - 4, GR.8, YELLOW ZINC PLATED
19	Varies	REPHASING CYLINDER CHECK PAGES 36-40

PARTS DETAILS – SECTIONS, 6-1/2'

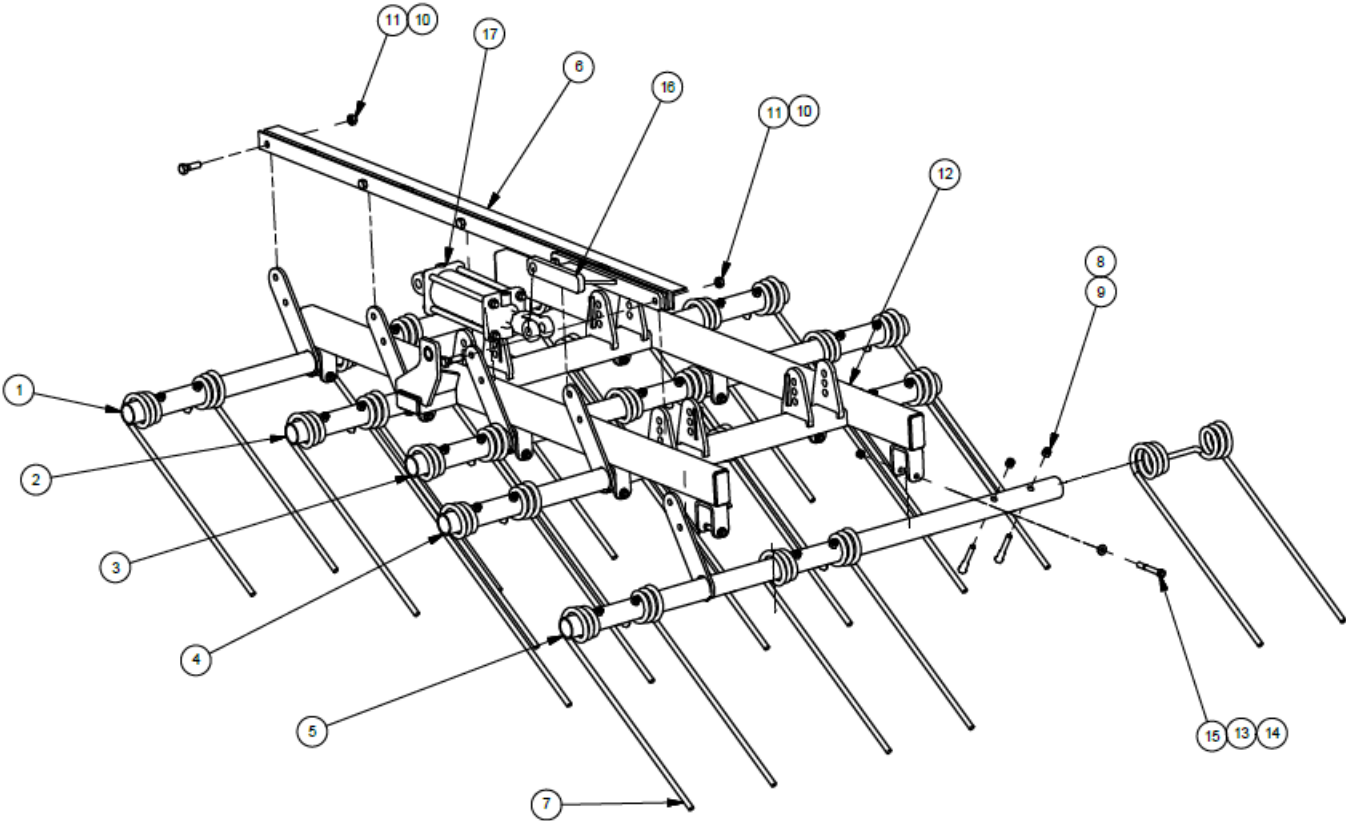

PARTS DETAILS – SECTIONS, 6-1/2'

ITEM #	PART #	DESCRIPTION
	160-0585	HARROW SECTION, 5-BAR, 6-1/2'
1	105-1260	5 BAR, PIPE 1, 6-1/2'
2	105-1261	5 BAR, PIPE 2, 6-1/2'
3	105-1262	5 BAR, PIPE 3, 6-1/2'
4	105-1331	5 BAR, PIPE 4, 6-1/2'
5	105-1332	5 BAR, PIPE 5, 6-1/2'
6	116-8002r1	HARROW ADJUSTING LINKAGE
7*	404-0028	9/16" X 28" HARROW TINE
7*	404-0035	9/16" X 28" HARROW TINE, W/ WEAR GUARD
7*	404-0030	5/8" X 28" HARROW TINE
7*	404-0037	5/8" X 28" HARROW TINE, W/ WEAR GUARD
8	545-0015	1/2 X 3-3/4 HIGH HEAD HARROW BOLT
9	526-7008	NUT, NYLOCK, 1/2-13 UNC, GR.5, YELLOW ZINC PLATED
10	526-1016	BOLT, 5/8-11 UNC - 2, GR.5, YELLOW ZINC PLATED
11	526-6106	NUT, STOVER LOCK, 5/8-11 UNC, GR.5, YELLOW ZINC PLATED
12	105-1073	6-1/2' JUMBO HARROW FRAME WELDED
13	550-5308	WASHER, FLAT, 1/2" - SAE, GR.5, YELLOW ZINC PLATED
14	526-6105	NUT, STOVER LOCK, 1/2-13 UNC, GR.5, YELLOW ZINC PLATED
15	530-0754	BOLT, 1/2-13 UNC - 4, GR.8, YELLOW ZINC PLATED
16	112-0132	11' TINE ADJUSTMENT WELDMENT
17	030-5740	Cylinder- 4 x 8 - 1-3/8 Shaft, 3/4 ORB Ports 90° to Pins (40TP08-137) (639964)

PARTS DETAILS – TINE RETAINERS

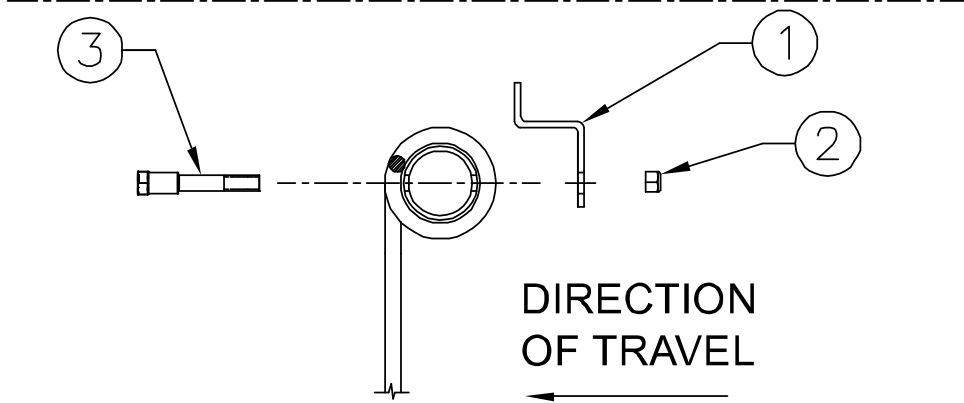
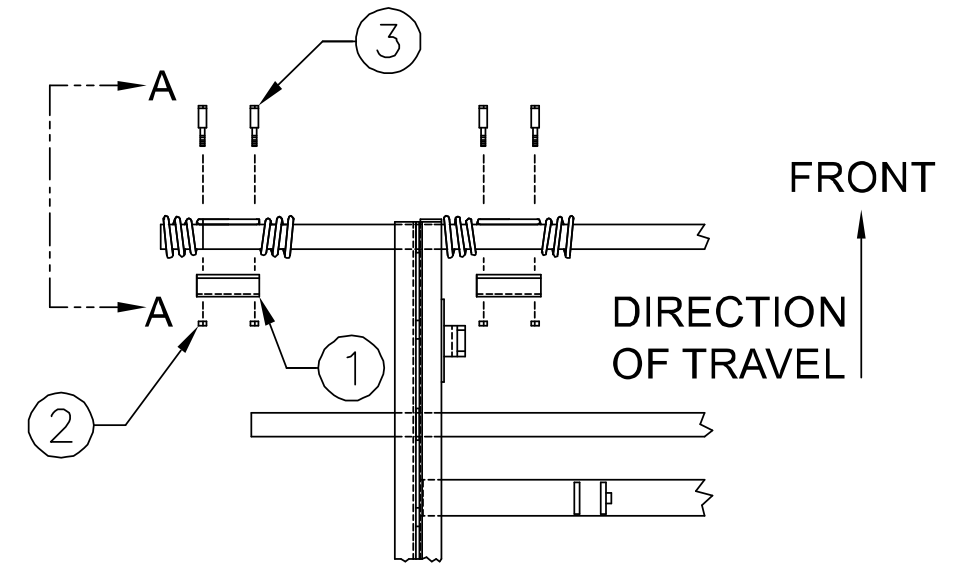
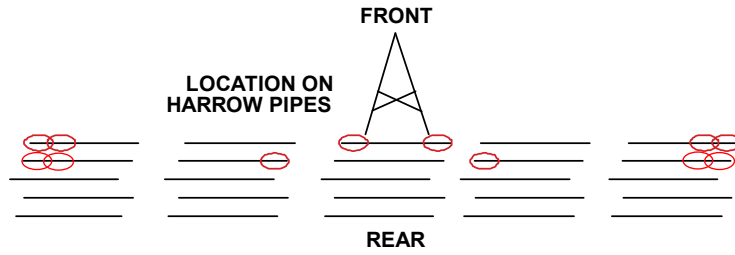

DETAIL A-A

ITEM #	PART #	DESCRIPTION
1*	112-0595	Universal Tine Retainer Clip Weldment
1*	839-1832	Tine Retainer, 5 Bar
2	526-6105	1/2" Stover Lock Nut, NC, Gr.5, Pltd.
3	545-0015	1/2" x 3-3/4" High Harrow Head Bolt, NC, Gr.5, Pltd.

PARTS DETAILS – TINE ANGLE INDICATOR

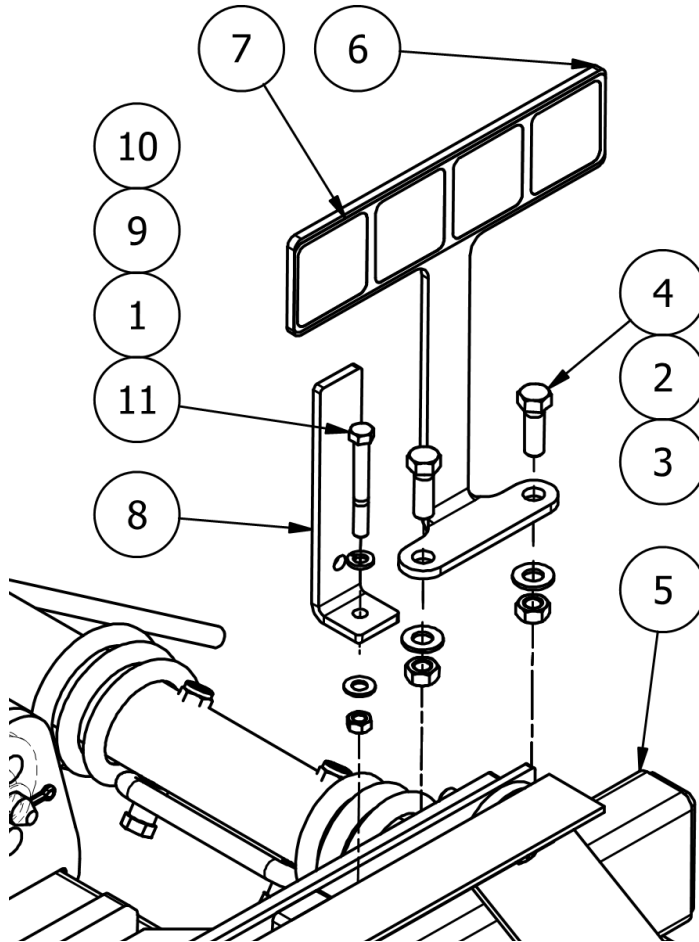

ITEM #	PART #	DESCRIPTION
1	526-6103	NUT, STOVER LOCK, 3/8-16 UNC, GR.5, YELLOW ZINC PLATED
2	526-6105	NUT, STOVER LOCK, 1/2-13 UNC, GR.5, YELLOW ZINC PLATED
3	550-5308	WASHER, FLAT, 1/2" - SAE, GR.5, YELLOW ZINC PLATED
4	526-0812	BOLT, 1/2-13 UNC - 1.5, GR.5, YELLOW ZINC PLATED
5	VARIES	OUTER MOST 11' HARROW SECTION
6	839-1242	TINE ADJ. SIGN BACKGROUND
7	060-0091	1234 HARROW TINE DECAL
8	839-1881	PLATE, INDICATOR, TINE ANGLE
9	551-5006	WASHER, SPRING, INCH, YELLOW ZINC PLATED
10	550-5306	WASHER, FLAT, 3/8" - SAE, GR.5, YELLOW ZINC PLATED
11	526-0624	BOLT, 3/8-16 UNC - 3, GR.5, YELLOW ZINC PLATED

PARTS DETAILS – LIGHT KIT & SLOW MOVING SIGN

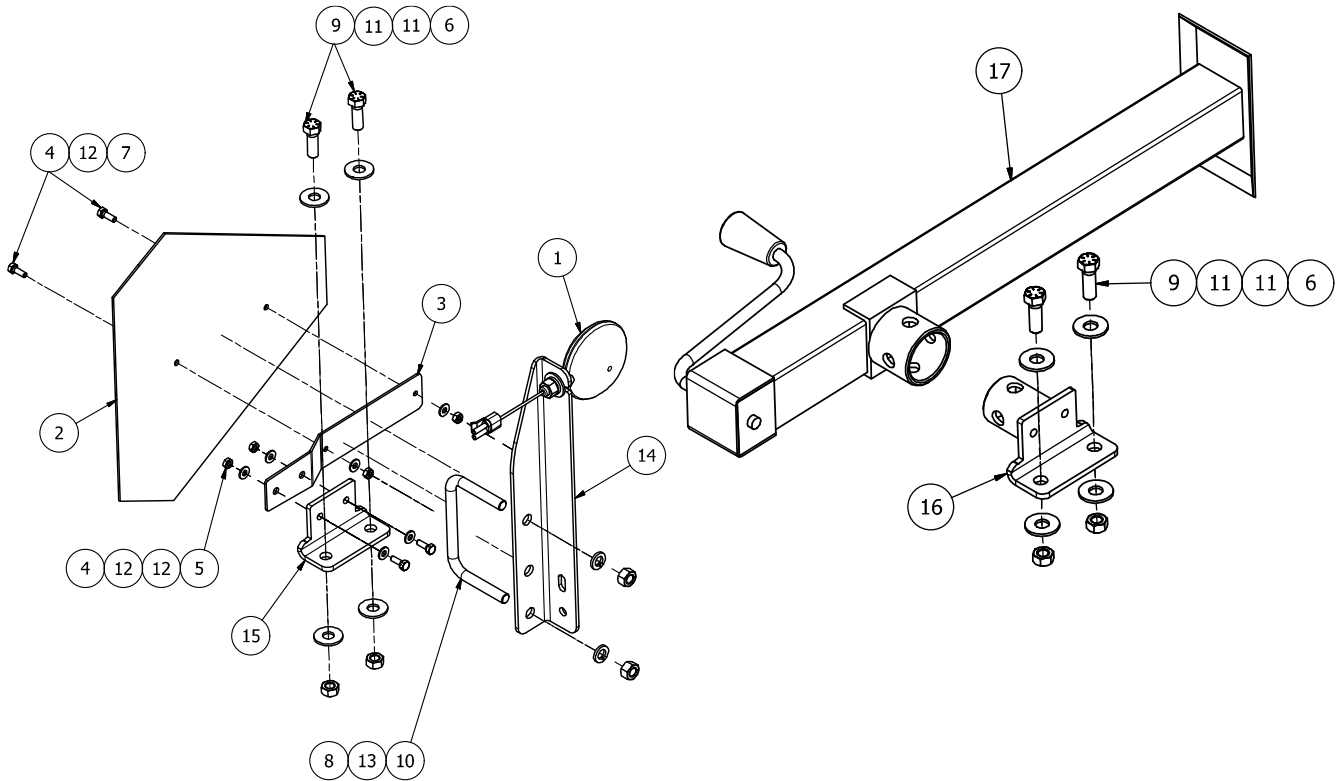

ITEM #	PART #	DESCRIPTION
1*	417-0019	RED WARNING LIGHT C/W HARDWARE
1*	417-0018	AMBER WARNING LIGHT C/W HARDWARE
2	424-0001	SLOW MOVING SIGN (SMV)
3	424-0002	SLOW MOVING SIGN SPADE
4	526-0406	BOLT, 1/4-20 UNC - 0.75, GR.5, YELLOW ZINC PLATED
5	526-6102	NUT, STOVER LOCK, 1/4-20 UNC, GR.5, YELLOW ZINC PLATED
6	526-6105	NUT, STOVER LOCK, 1/2-13 UNC, GR.5, YELLOW ZINC PLATED
7	526-6204	NUT, HEX, INCH, GRADE 5, YELLOW ZINC PLATED
8	526-6208	NUT, HEX, INCH, GRADE 5, YELLOW ZINC PLATED
9	530-0740	BOLT, 1/2-13 UNC - 1.5, GR.8, YELLOW ZINC PLATED
10	546-5157	4.5625 x 5 U-BOLT, SQUARE, ZINC PLATED
11	550-5208	WASHER, FLAT, 1/2" - USS, GR.5, YELLOW ZINC PLATED
12	550-5304	WASHER, FLAT, 1/4" - SAE, GR.5, YELLOW ZINC PLATED
13	551-5008	WASHER, SPRING, 1/2, GR.5, YELLOW ZINC PLATED
14	839-1762	RH, LIGHT BRACKET, FRONT
15	839-1878	BRACKET, SMV SIGN MOUNT, MH-7200
16	105-1193	7-BAR HARROW JACK STUB
17	420-0168	20-40" SIDEWIND JACK
	040-0029	LIGHT KIT, HH-8268 & 78 (not shown)
	040-0030	LIGHT KIT, HH-8245 & 55 (not shown)

PARTS DETAILS – LIGHT KIT & SLOW MOVING SIGN

PROFILED LIFT ARMS

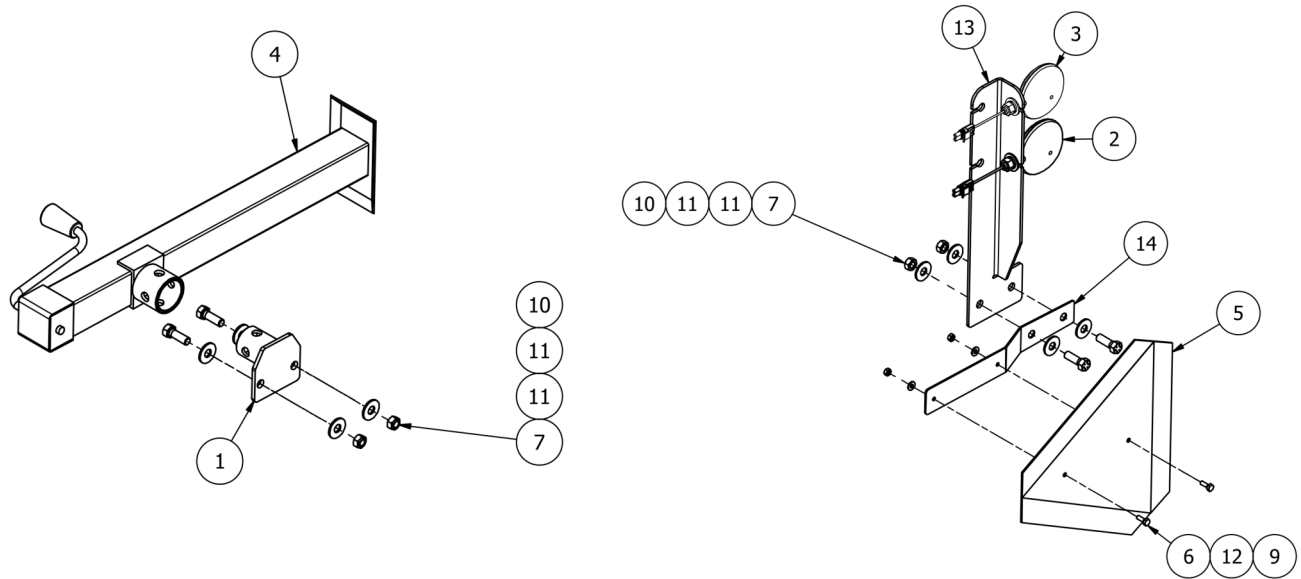

ITEM #	PART #	DESCRIPTION
1	105-1345	JACK MOUNT WELDMENT, PROFILED LIFT ARM
2	417-0018	AMBER WARNING LIGHT C/W HARDWARE
3	417-0019	RED WARNING LIGHT C/W HARDWARE
4	420-0168	5000lb. 20" SQUARE SIDEWIND JACK 20.1"RL
5	424-0001	SLOW MOVING SIGN (SMV)
6	526-0406	BOLT, 1/4-20 UNC - 0.75, GR.5, YELLOW ZINC PLATED
7	526-6105	NUT, STOVER LOCK, 1/2-13 UNC, GR.5, YELLOW ZINC PLATED
8	526-6109	NUT, STOVER LOCK, 1-8 UNC, GR.5, YELLOW ZINC PLATED
9	526-6204	NUT, HEX, INCH, GRADE 5, YELLOW ZINC PLATED
10	530-0740	BOLT, 1/2-13 UNC - 1.5, GR.8, YELLOW ZINC PLATED
11	550-5208	WASHER, FLAT, 1/2" - USS, GR.5, YELLOW ZINC PLATED
12	550-5304	WASHER, FLAT, 1/4" - SAE, GR.5, YELLOW ZINC PLATED
13	839-2109	UNIVERSAL, LIGHT BRACKET, PROFILED LIFT ARM
14	839-2110	SLOW MOVING SIGN SPADE, PROFILED LIFT ARM
	040-0029	LIGHT KIT, HH-8268 & 78 (not shown)
	040-0030	LIGHT KIT, HH-8245 & 55 (not shown)

PARTS DETAILS – PERFECT HITCH

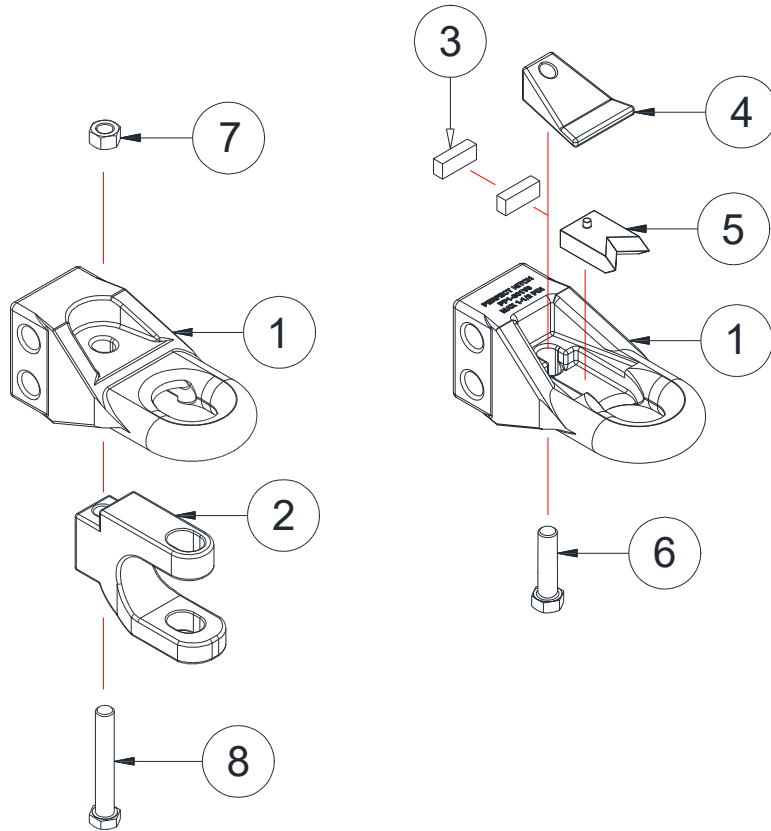

ITEM #	PART #	DESCRIPTION
1	423-0005	Base Hitch (PP1-301VH)
2	423-0006	Clevis (PP1-208VR-10)
3	423-0019	Neoprene Cushion (PP1-205H)
4	423-0017	Top Plate Perfect Hitch (PP1-302V)
5	423-0018	V-Block (PP1-203VR)
6	526-1224	3/4" x 3" Capscrew, NC, Gr.5, Pltd.
7	526-6107	3/4" Stover Lock Nut, NC, Gr.B, Pltd.
8	526-1241	3/4" x 5-1/2" Capscrew, NC, Gr.5, Pltd.

The sliding V-block has a polyurethane cushion which is made to flex. The cushion also acts as a shock absorber to reduce driveline stress, giving driveline components longer life. **Do not remove all the cushions! Install the perfect hitch components with bolt head on the bottom and the top plate on top.**

Always adjust the V-block to your tractor draw pin size by following these steps:

1. Remove top plate by unscrewing 3/4" bolt from bottom of Perfect Hitch and lifting top plate off.
2. The polyurethane cushion can be laid flat to achieve an extra 1/4" of adjustment.
3. If more closure is needed metal spacers (not supplied) can be placed behind the cushions to push the V-block forward and closer to the draw pin hole to tractor draw pin size.
4. Replace top plate and re-install 3/4" bolt tightly (Approx. 200 ft/lb).

PARTS DETAILS – CENTER HUB & SPINDLE

NOTE: 812 Hub & spindles are used on ALL center frames.

If 12.5Lx15 tires are used on the wings, 812s are used throughout the machine.

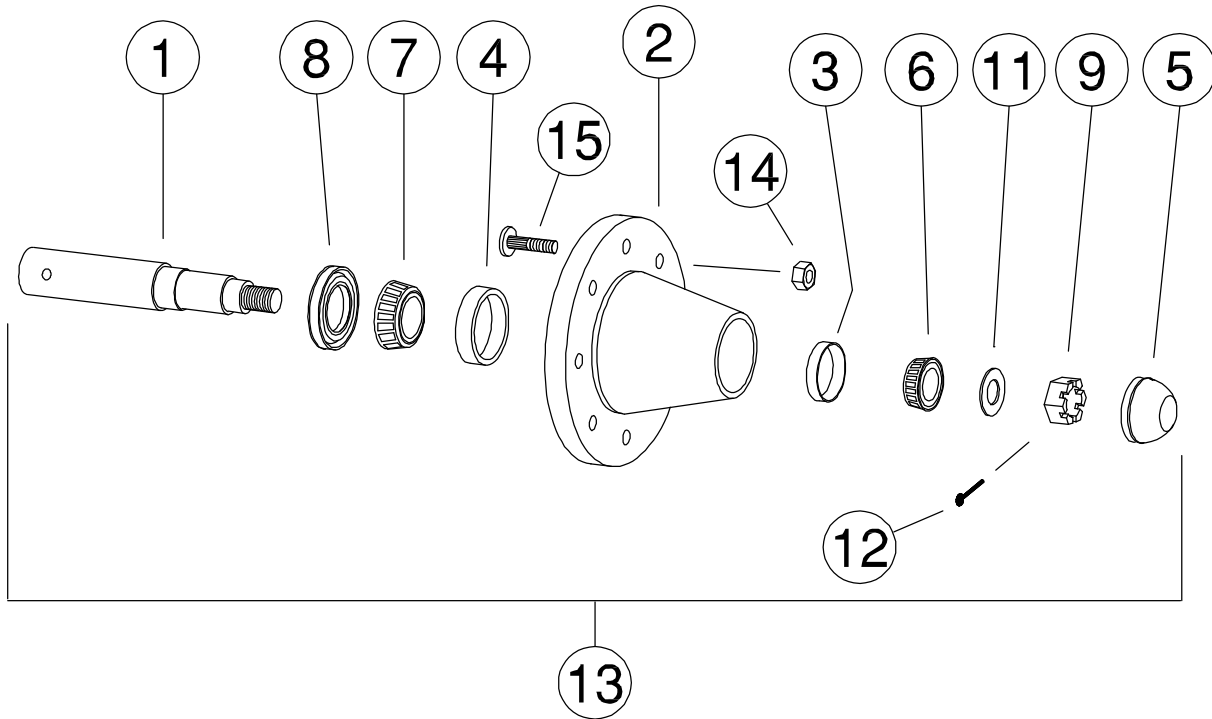

ITEM #	PART #	DESCRIPTION
1	203-6044	812 Spindle, Ø2-1/2" X 11-3/4" Long
2	200-6011	812 Hub (complete)
3	201-6016	Outer Cup LM2720
4	201-6017	Inner Cup 3720
5	202-6013	DC 17 Dust Cap
6	290-6013	Outer Bearing, 2790
7	290-6014	Inner Bearing, 3780
8	295-6016	SE 17 Seal
9	534-7816	1" Castle Nut, NF, Gr.5, Black
11	554-5303	1" Spindle Washer, Black
12	556-0614	3/16" x 1-3/4" Cotter Pin, Pltd.
13	120-1246	812 Hub & Spindle Assembly
14	543-5563	9/16" Wheel Nut, UNF
15	543-5564	9/16" Wheel Stud

PARTS DETAILS – WING HUB & SPINDLE

NOTE: 618 Hub & spindles are used on wings with 11Lx15 tires ONLY

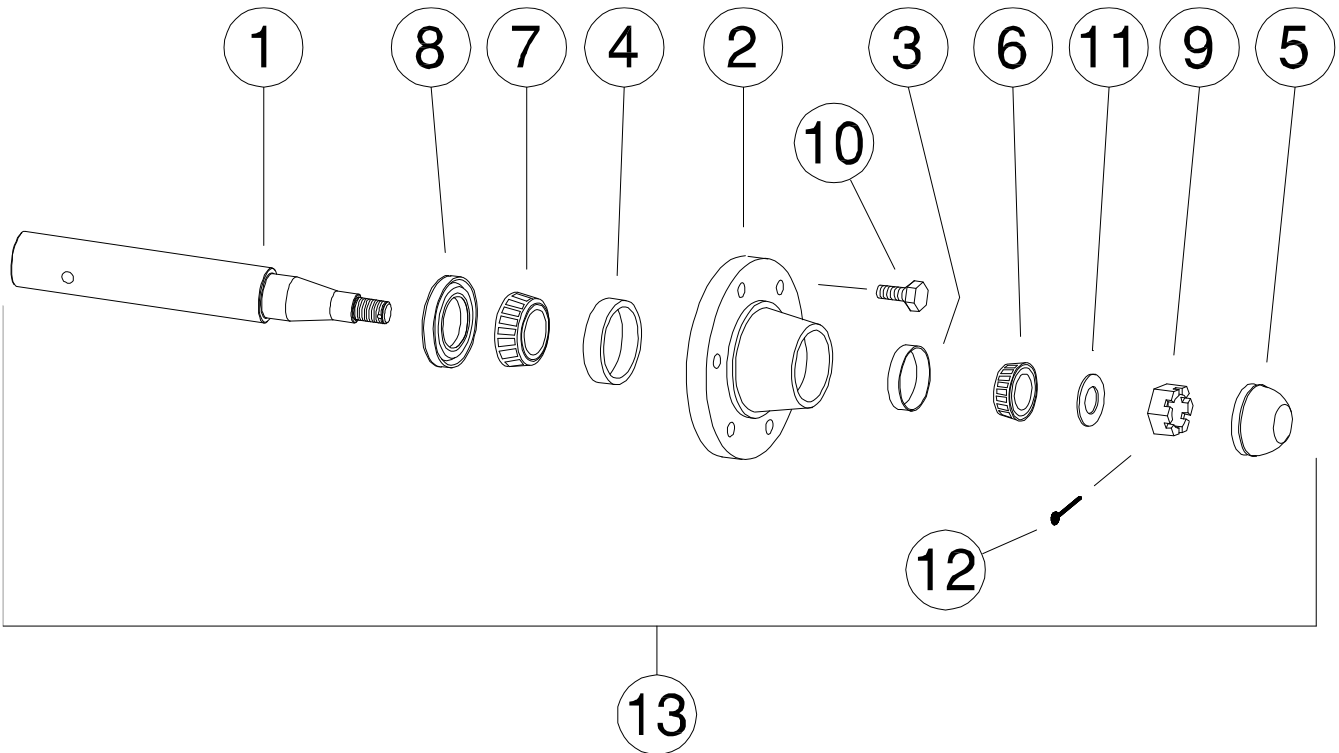

ITEM #	PART #	DESCRIPTION
1	203-6021	618 Spindle, Ø2-1/2" X 14-1/4" Long
2	200-6009	618 Hub (complete)
3	201-5523	Outer Cup (LM48510)
4	201-5525	Inner Cup (LM25520)
5	202-6005	Dust Cap (DC 15)
6	290-5515	Outer Wheel Bearing (LM48548)
7	290-5519	Inner Wheel Bearing (LM25580)
8	295-5576	Seal (SE30)
9	534-7816	1" Castle Nut, NF
10	543-5562	9/16" Wheel Stud UNF
11	554-5303	1" Spindle Washer WA12
12	556-0614	3/16" x 1-3/4" Cotter Pin, Black
13	120-1237	618 Hub & Spindle Assembly

PARTS DETAILS – HYDRAULICS, HITCH

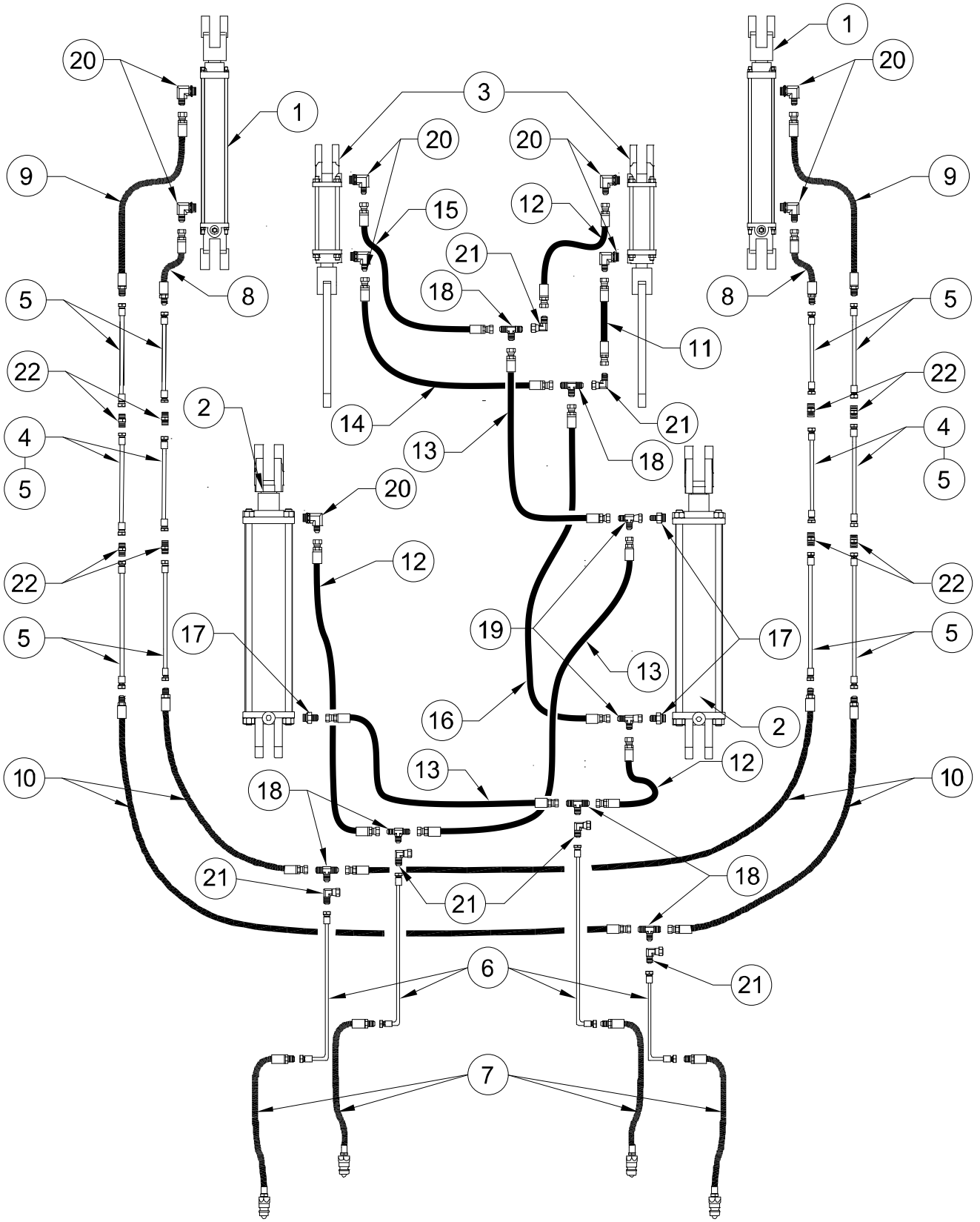

PARTS DETAILS – HYDRAULICS, HITCH

ITEM #	PART #	DESCRIPTION
1	030-5979	2" X 12" HYDRAULIC CYLINDER – ORB
2	030-5985	4" X 24" HYDRAULIC CYLINDER, 1.50" ROD – ORB
3	030-5999	2" X 4" HYDRAULIC CYLINDER – ORB
4	311-2083	3/8" HYDRAULIC STEEL LINES- 83"
5	311-2132	3/8" HYDRAULIC STEEL LINES- 132"
6	311-2157	3/8" HYDRAULIC STEEL LINES - BENT- 157"
7	313-5096	3/8" JIC M X 1/2" NPT M HYDRAULIC HOSE- 96"
8	313-7812	3/8" JIC M X 3/8" JIC SW F HYDRAULIC HOSE- 12"
9	313-7828	3/8" JIC M X 3/8" JIC SW F HYDRAULIC HOSE- 28"
10	313-7895	3/8" JIC M X 3/8" JIC SW F HYDRAULIC HOSE- 144"
11	313-7928	3/8" JIC SW F X 3/8" JIC SW F HYDRAULIC HOSE– 28"
12	313-7937	3/8" JIC SW F X 3/8" JIC SW F HYDRAULIC HOSE- 37"
13	313-7955	3/8" JIC SW F X 3/8" JIC SW F HYDRAULIC HOSE- 55"
14	313-7971	3/8" JIC SW F X 3/8" JIC SW F HYDRAULIC HOSE– 71"
15	313-7977	3/8" JIC SW F X 3/8" JIC SW F HYDRAULIC HOSE– 77"
16	313-7985	3/8" JIC SW F X 3/8" JIC SW F HYDRAULIC HOSE– 85"
17	316-0302	1/2" ORB M X 3/8" JIC MALE – ADAPTOR
18	318-5704	HYDRAULIC TEE - 3/8" JIC M (X2 RUN & BRANCH)
19	318-5710	HYDRAULIC TEE - 3/8" JIC M (X1 RUN, BRANCH) X 3/8" JIC SW F (X1 RUN)
20	319-5710	1/2" ORB M X 3/8" JIC M - 90° ELBOW
21	319-5714	3/8" JIC M X 3/8" JIC SW F - 90° ELBOW
22	324-0031	3/8" JIC NIPPLE

PARTS DETAILS – HYDRAULIC SCHEMATIC, 8245

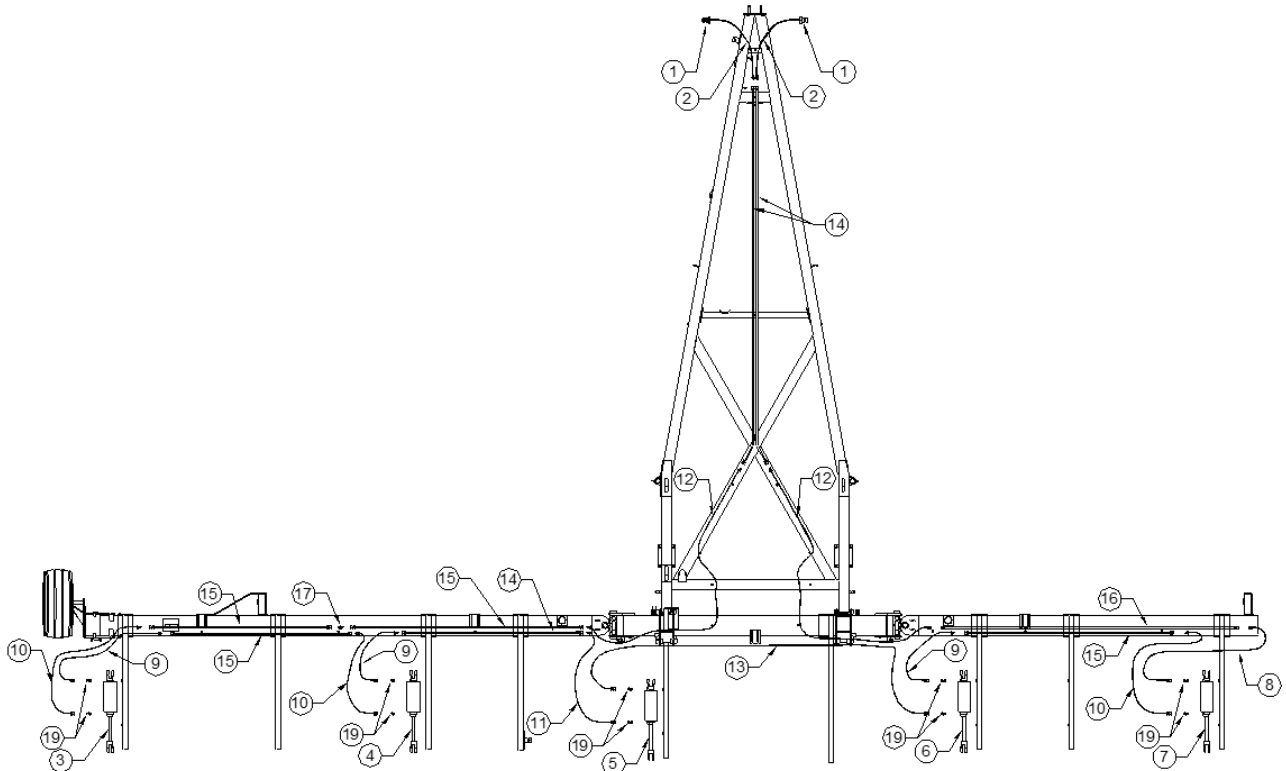

ITEM #	PART #	DESCRIPTION	QTY
1	308-0001	Pioneer Coupling	2
2	313-5096	3/8 JIC M x 1/2 NPT M - 96" Hyd Hose	2
3	030-5734	2-1/2 x 8 BP Hyd Cyl - 1/2 ORB	1
4	030-5735	2-3/4 x 8 BP Hyd Cyl - 1/2 ORB	1
5	030-5736	3 x 8 BP Hyd Cyl - 1/2 ORB	1
6	030-5737	3-1/4 x 8 BP Hyd Cyl - 1/2 ORB	1
7	030-5738	3-1/2 x 8 BP Hyd. Cyl - 1/2 ORB	1
8	313-7863	3/8 JIC M x 3/8 JIC Sw F - 63" Hyd Hose	1
9	313-7871	3/8 JIC M x 3/8 JIC Sw F - 71" Hyd Hose	3
10	313-7885	3/8 JIC M x 3/8 JIC Sw F - 85" Hyd Hose	3
11	313-7899	3/8 JIC M x 3/8 JIC Sw F - 113" Hyd Hose	1
12	313-7895	3/8 JIC M x 3/8 JIC Sw F - 144" Hyd Hose	2
13	313-7904	3/8 JIC Sw F x 3/8 JIC Sw F - 270" Hyd Hose	1
14	311-2066	3/8 Hydraulic Line - 66"	1
15	311-2083	3/8 Hydraulic Line - 83"	4
16	311-2132	3/8 Hydraulic Line - 132"	1
17	311-2157	3/8 Hydraulic Line - 157"	2
18	324-0031	3/8 JIC Nipple	3
19	319-5729	1/2 ORB M x 3/8 JIC M - 45° Elbow	10

PARTS DETAILS – HYDRAULIC SCHEMATIC, 8255

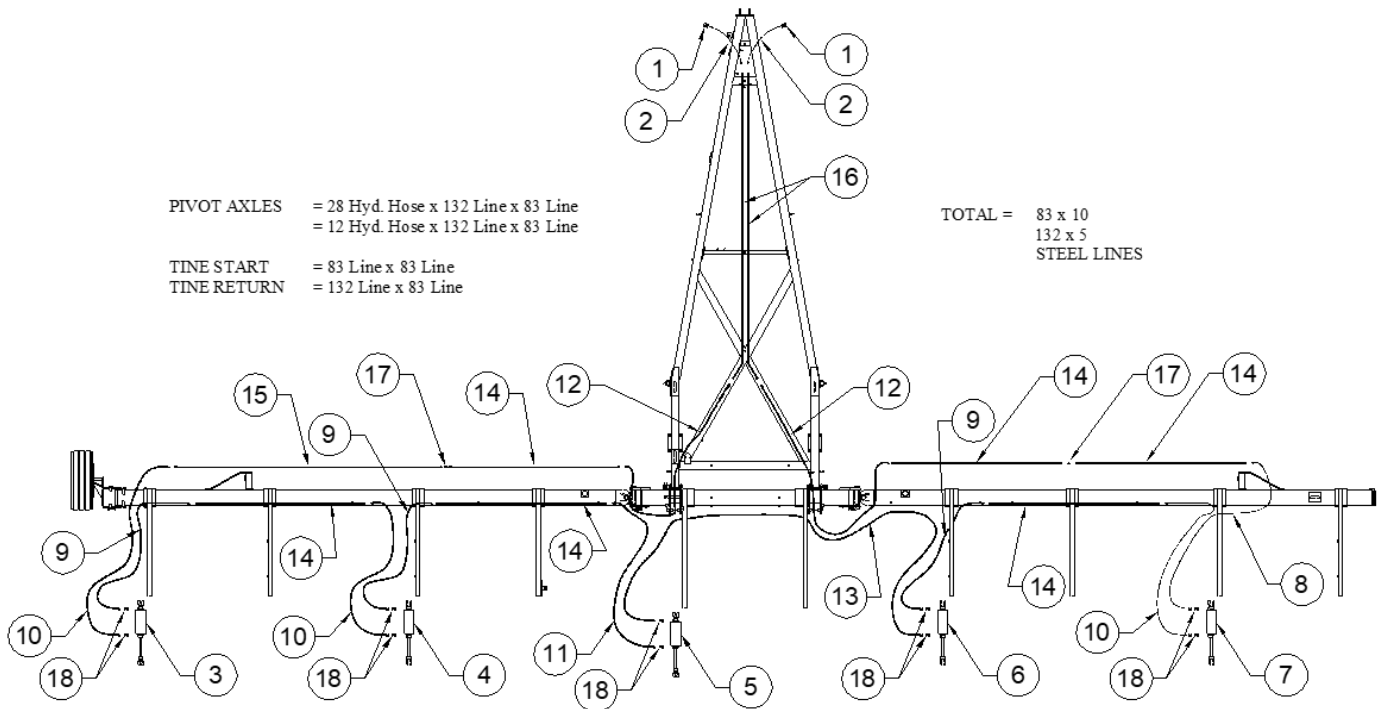

ITEM #	PART #	DESCRIPTION	QTY
1	308-0001	Pioneer Coupling	2
2	313-5096	3/8 JIC M x 1/2 NPT M - 96" Hyd Hose	2
3	030-5734	2-1/2 x 8 BP Hyd Cyl - 1/2 ORB	1
4	030-5735	2-3/4 x 8 BP Hyd Cyl - 1/2 ORB	1
5	030-5736	3 x 8 BP Hyd Cyl - 1/2 ORB	1
6	030-5737	3-1/4 x 8 BP Hyd Cyl - 1/2 ORB	1
7	030-5738	3-1/2 x 8 BP Hyd. Cyl - 1/2 ORB	1
8	313-7863	3/8 JIC M x 3/8 JIC Sw F - 63" Hyd Hose	1
9	313-7871	3/8 JIC M x 3/8 JIC Sw F - 71" Hyd Hose	3
10	313-7885	3/8 JIC M x 3/8 JIC Sw F - 85" Hyd Hose	3
11	313-7899	3/8 JIC M x 3/8 JIC Sw F - 113" Hyd Hose	1
12	313-7895	3/8 JIC M x 3/8 JIC Sw F - 144" Hyd Hose	2
13	313-7904	3/8 JIC Sw F x 3/8 JIC Sw F - 270" Hyd Hose	1
14	311-2083	3/8 Hydraulic Line - 83"	6
15	311-2132	3/8 Hydraulic Line - 132"	1
16	311-2157	3/8 Hydraulic Line - 157"	2
17	324-0031	3/8 JIC Nipple	2
18	319-5729	1/2 ORB M x 3/8 JIC M - 45° Elbow	10

PARTS DETAILS – HYDRAULIC SCHEMATIC, 8268

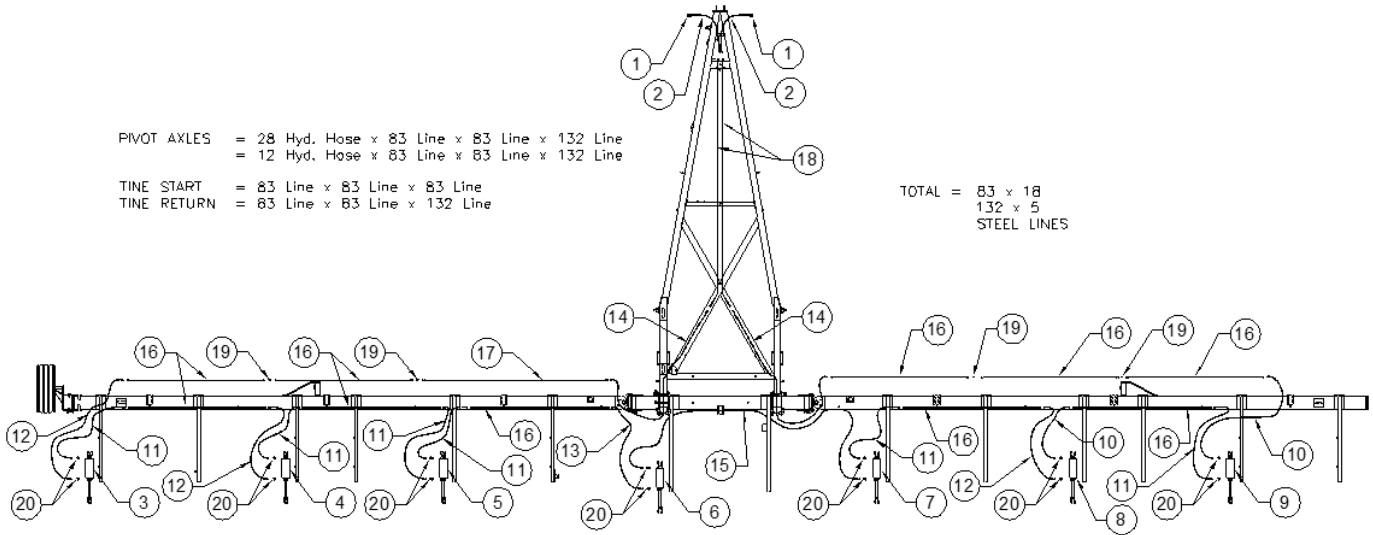

ITEM #	PART #	DESCRIPTION	QTY
1	308-0001	Pioneer Coupling	2
2	313-5096	3/8" JIC M x 1/2" NPT M - 96" Hyd Hose	2
3	30-5734	2-1/2" x 8" BP Hyd Cyl - 1/2" ORB	1
4	30-5735	2-3/4" x 8" BP Hyd Cyl - 1/2" ORB	1
5	30-5736	3" x 8" BP Hyd Cyl - 1/2" ORB	1
6	30-5737	3-1/4" x 8" BP Hyd Cyl - 1/2" ORB	1
7	30-5738	3-1/2" x 8" BP Hyd Cyl - 1/2" ORB	1
8	30-5739	3-3/4" x 8" BP Hyd Cyl - 1/2" ORB	1
9	30-5740	4" x 8" BP Hyd Cyl - 1/2" ORB	1
10	313-7863	3/8" JIC M x 3/8 JIC Sw F - 63" Hyd Hose	2
11	313-7871	3/8" JIC M x 3/8 JIC Sw F - 71" Hyd Hose	6
12	313-7885	3/8" JIC M x 3/8 JIC Sw F - 85" Hyd Hose	3
13	313-7899	3/8" JIC M x 3/8 JIC Sw F - 113" Hyd Hose	1
14	313-7895	3/8 JIC M x 3/8 JIC Sw F - 144" Hyd Hose	2
15	313-7904	3/8 JIC Sw F x 3/8 JIC Sw F - 270" Hyd Hose	1
16	311-2083	3/8" Hydraulic Line - 83"	10
17	311-2132	3/8" Hydraulic Line - 132"	1
18	311-2157	3/8" Hydraulic Line - 157"	2
19	324-0031	3/8" JIC Nipple	4
20	319-5729	1/2 ORB M x 3/8 JIC M - 45° Elbow	14

PARTS DETAILS – HYDRAULIC SCHEMATIC, 8278

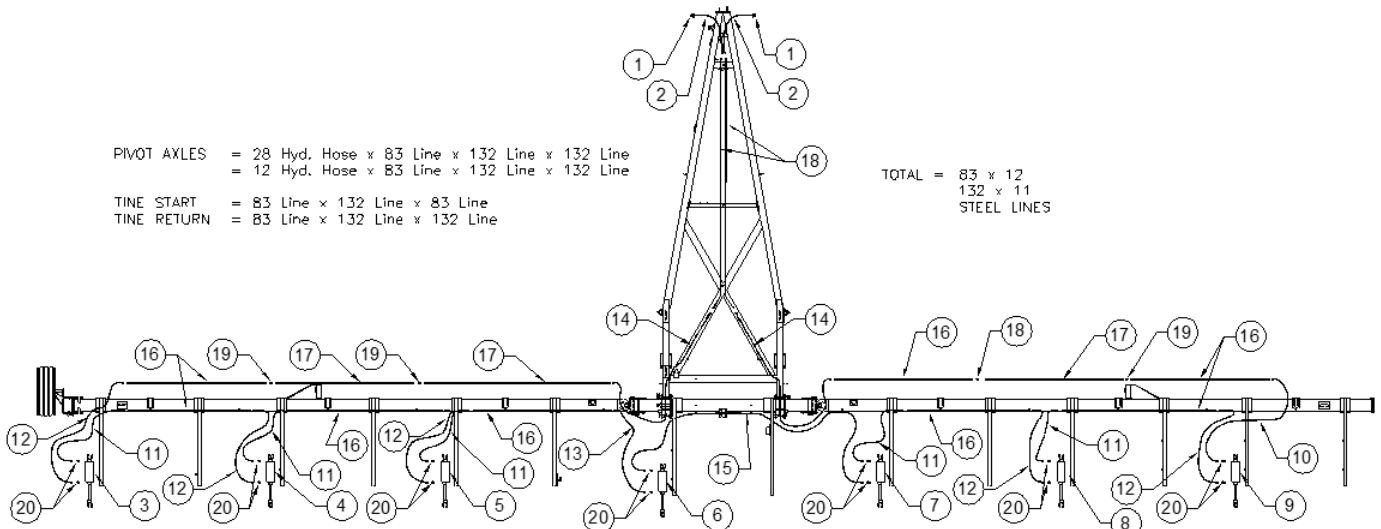

ITEM #	PART #	DESCRIPTION	QTY
1	308-0001	Pioneer Coupling	2
2	313-5096	3/8" JIC M x 1/2" NPT M - 96" Hyd Hose	2
3	30-5734	2-1/2" x 8" BP Hyd Cyl - 1/2" ORB	1
4	30-5735	2-3/4" x 8" BP Hyd Cyl - 1/2" ORB	1
5	30-5736	3" x 8" BP Hyd Cyl - 1/2" ORB	1
6	30-5737	3-1/4" x 8" BP Hyd Cyl - 1/2" ORB	1
7	30-5738	3-1/2" x 8" BP Hyd Cyl - 1/2" ORB	1
8	30-5739	3-3/4" x 8" BP Hyd Cyl - 1/2" ORB	1
9	30-5740	4" x 8" BP Hyd Cyl - 1/2" ORB	1
10	313-7863	3/8" JIC M x 3/8 JIC Sw F - 63" Hyd Hose	1
11	313-7871	3/8" JIC M x 3/8 JIC Sw F - 71" Hyd Hose	5
12	313-7885	3/8" JIC M x 3/8 JIC Sw F - 85" Hyd Hose	5
13	313-7899	3/8" JIC M x 3/8 JIC Sw F - 113" Hyd Hose	1
14	313-7895	3/8 JIC M x 3/8 JIC Sw F - 144" Hyd Hose	2
15	313-7904	3/8 JIC Sw F x 3/8 JIC Sw F - 270" Hyd Hose	1
16	311-2083	3/8" Hydraulic Line - 83"	8
17	311-2132	3/8" Hydraulic Line - 132"	3
18	311-2157	3/8" Hydraulic Line - 157"	2
19	324-0031	3/8" JIC Nipple	4
20	319-5729	1/2 ORB M x 3/8 JIC M - 45° Elbow	14

PARTS DETAIL – CYLINDERS

MONARCH 4" X 24" (40THC24-150)

MONARCH PART NUMBER 671645

RITE WAY PART NUMBER 030-5985

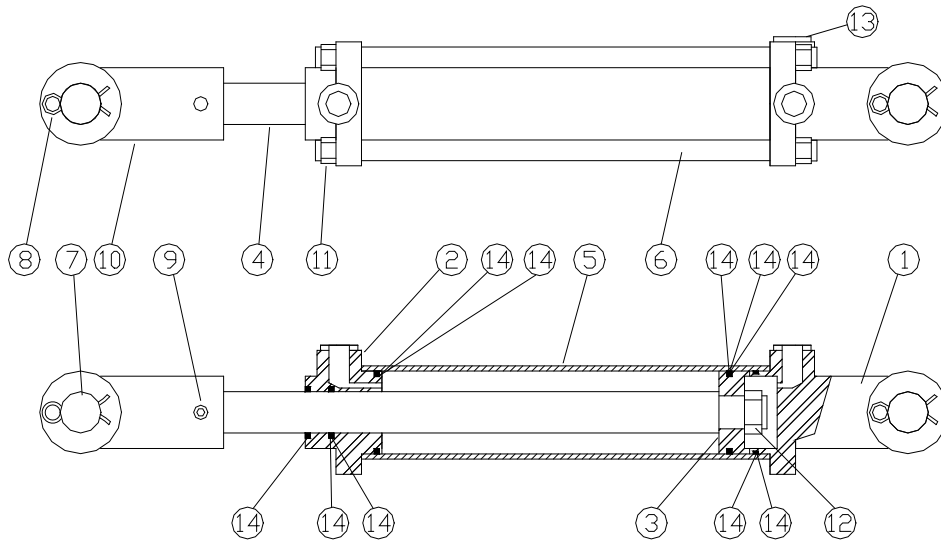

ITEM #	PART #	DESCRIPTION
1	492680	Clevis Cap 4" x 3/4" ORB-1.00
2	492686	Rod Cap - 4" x 1-1/2" - 3/4"ORB
3	492527	Piston - 4" Dia. CST DI
4	492615	Rod - 1-1/2" Dia. TL x 26"
5	467324	Tube - 4" x 24" 5/8" TR
6	492354	Tie Rod - 5/8" x 24"
7	134953	Pin Ø1" x 3.37" for Cotter
8	134952	Hair Pin - .105 Dia.
9	148390	SC SCKT Set 3/8" UNC x 1/2" KNUR
10	492652	Rod Clevis 1-1/4"
11	128271	Hex Nut - 5/8" UNC Gr.5
12	129110	Hex Nut - 1" - 14 UNS Gr.5
13	186562	Plug - 3/4" - 16 UNF SOC HD STR-THD
14	639580	Seal Kit - 4" x 1-1/2"

PARTS DETAIL – CYLINDERS

MONARCH 2-1/2" X 8" BP (25TP08-112)

MONARCH PART NUMBER 639521

RITE WAY PART NUMBER 030-5734

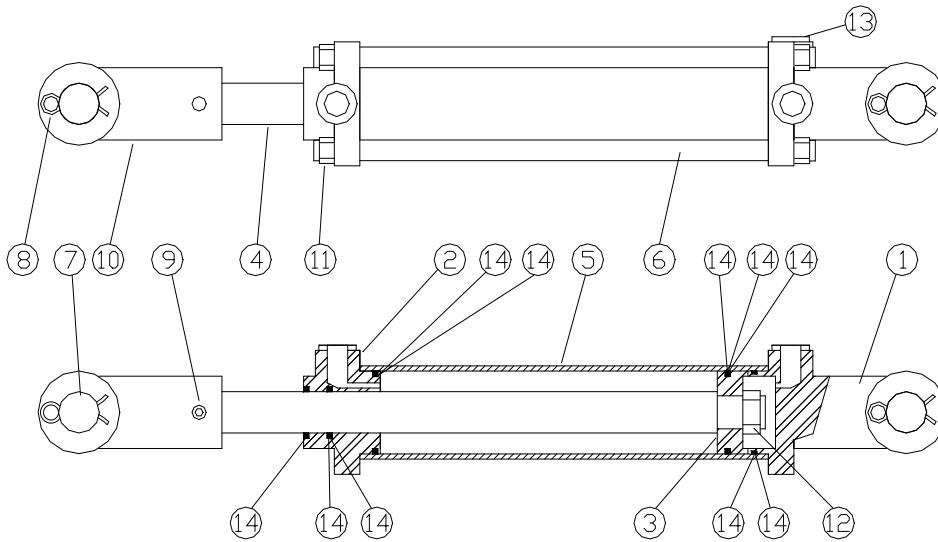

ITEM #	PART #	DESCRIPTION
1	492674	Clevis Cap 2-1/2" ORB
2	492673	Rod Cap 2-1/2" x 1-1/8" ORB
3	494726	Piston * R1 * 2-1/2" WPTR
4	492699	Rod 1.125 ASAE 8
5	464263	Tube Weld 2-1/2" x 8" TP
6	492218	Tie Rod 3/8" x 8"
7	469528	Pin 1" Dia. for Cotter
8	135995	Cotter Pin 3/16" x 1-1/2" Hammerlock
9	148390	SC SCKT Set 3/8" UNC x 1/2" KNUR
10	492650	Rod Clevis 1-1/8"
11	128230	Nut Hex 3/8" UNC
12	130556	Nut Hex 3/4" UNF Gr.A Unitorque
13	186562	Plug 3/4"-16 UNF SOC HD STR-THD
14	639555	Seal Kit - 2-1/2" x 1-1/8"

PARTS DETAIL – CYLINDERS

MONARCH 2-3/4" X 8" BP (27TP08 - 112)
MONARCH PART NUMBER 639522
RITE WAY PART NUMBER 030-5735

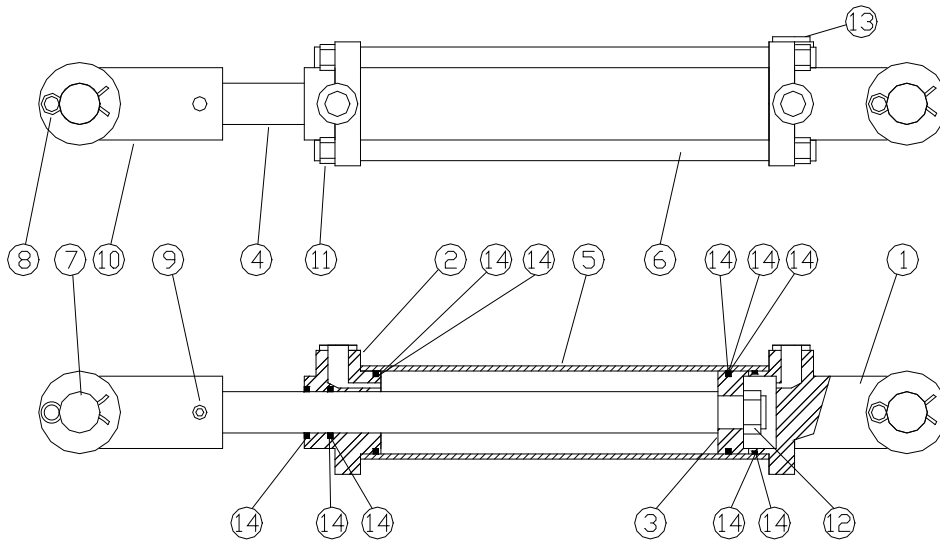

ITEM #	PART #	DESCRIPTION
1	492660	Clevis Cap 2-3/4" ORB
2	492661	Rod Cap 2-3/4" x 1-1/8" ORB
3	494727	Piston * R1 * 2-3/4" WPTR
4	492699	Rod 1-1/8" ASAE 8
5	464264	Tube Weld 2-3/4" x 8" TP
6	492278	Tie Rod 1/2" x 8"
7	469528	Pin 1" Dia. For Cotter
8	135995	Cotter Pin 3/16" x 1-1/2" Hammerlock
9	148390	SC SCKT Set 3/8" UNC x 1/2" KNUR
10	492650	Rod Clevis 1-1/8"
11	128250	Nut Hex 1/2" UNC
12	130556	Nut Hex 3/4" UNF Gr.A Unitorque
13	186562	Plug 3/4"-16 UNF SOC HD STR-THD
14	639557	Seal Kit 2-3/4" x 1-1/8"

PARTS DETAIL – CYLINDERS

MONARCH 3" X 8" BP (30TP08-125)
MONARCH PART NUMBER 639523
RITE WAY PART NUMBER 030-5736

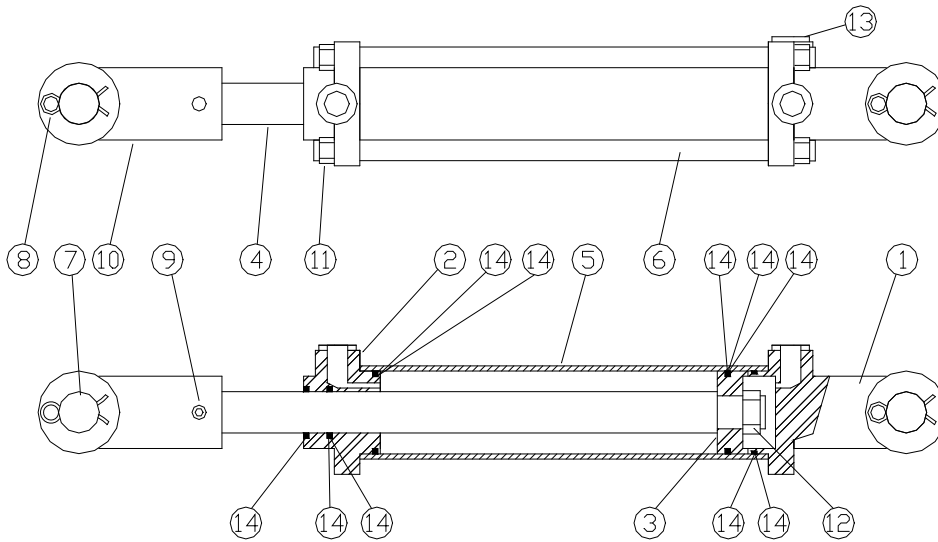

ITEM #	PART #	DESCRIPTION
1	492675	Clevis Cap 3" ORB
2	492670	Rod Cap 3" x 1-1/4" ORB
3	494719	Piston *R1 * 3" WPTR
4	492700	Rod 1-1/4" Dia. ASAE 8
5	464265	Tube Weld 3" x 8" TP
6	492278	Tie Rod 1/2" x 8"
7	469528	Pin 1" Dia For Cotter
8	135995	Cotter Pin 3/16" x 1-1/2" Hammerlock
9	148390	SC SCKT Set 3/8" UNC x 1/2" KNUR
10	492652	Rod Clevis 1-1/4"
11	128250	Nut Hex 1/2" UNC
12	130560	Nut Hex 1"-14 Gr.A Uitorque
13	186562	Plug 3/4"-16 UNF SOC HD STR-THD
14	639558	Seal Kit 3" x 1-1/4"

PARTS DETAIL – CYLINDERS

MONARCH 3-1/4" X 8" BP (32TP08-125)

MONARCH PART NUMBER 639524

RITE WAY PART NUMBER 030-5737

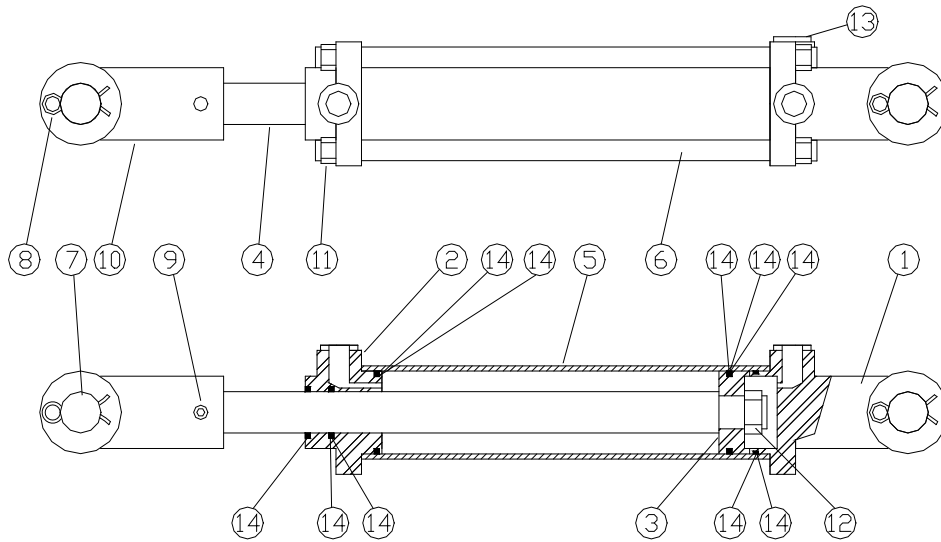

ITEM #	PART #	DESCRIPTION
1	492662	Clevis Cap 3-1/4" ORB
2	492664	Rod Cap 3-1/4" x 1-1/4" ORB
3	494737	Piston 3-1/4" TP
4	492700	Rod 1-1/4" Dia. ASAE 8
5	464266	Tube Weld 3-1/4" x 8" TP
6	492338	Tie Rod 5/8" x 8"
7	469528	Pin 1" Dia. For Cotter
8	135995	Cotter Pin 3/16" x 1-1/2" Hammerlock
9	148390	SC SCKT Set 3/8" UNC x 1/2" KNUR
10	492652	Rod Clevis 1-1/4"
11	128271	Nut Hex 5/8" UNF Grade 5
12	130560	Nut Hex 1"-14 Gr.A Uunitorque
13	186562	Plug 3/4"-16 UNF SOC HD STR-THD
14	639560	Seal Kit 3-1/4" x 1-1/4"

PARTS DETAIL – CYLINDERS

MONARCH 3-1/2" X 8" BP (35TP08-125)

MONARCH PART NUMBER 639962

RITE WAY PART NUMBER 030-5738

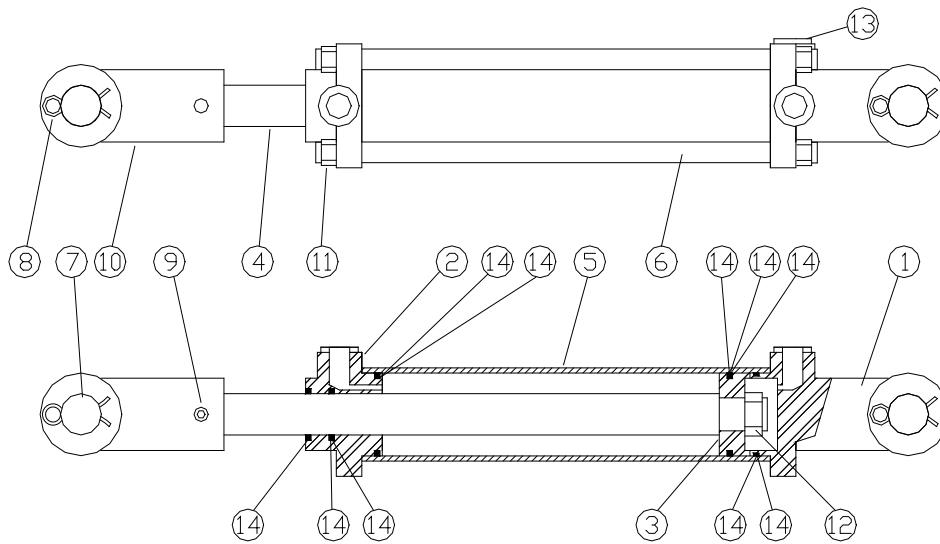

ITEM #	PART #	DESCRIPTION
1	492676	Clevis Cap 3-1/2" ORB
2	492677	Rod Cap 3-1/2" x 1-1/4" ORB
3	494738	Piston 3-1/2" TH/TP
4	492700	Rod 1-1/4" Dia. ASAE 8
5	464267	Tube Weld 3-1/2" x 8" TP
6	492338	Tie Rod 5/8" x 8"
7	469528	Pin 1" Dia. For Cotter
8	135995	Cotter Pin 3/16" x 1-1/2" Hammerlock
9	148390	SC SCKT Set 3/8" UNC x 1/2" KNUR
10	492652	Rod Clevis 1-1/4"
11	128271	Nut Hex 5/8" UNF
12	130560	Nut Hex 1"-14 Gr.A Uitorque
13	186562	Plug 3/4"-16 UNF SOC HD STR-THD
14	639561	Seal Kit 3-1/2" x 1-1/4"

PARTS DETAIL – CYLINDERS

MONARCH 3-3/4" X 8" BP (37TP08 - 137)

MONARCH PART NUMBER 639963

RITE WAY PART NUMBER 030-5739

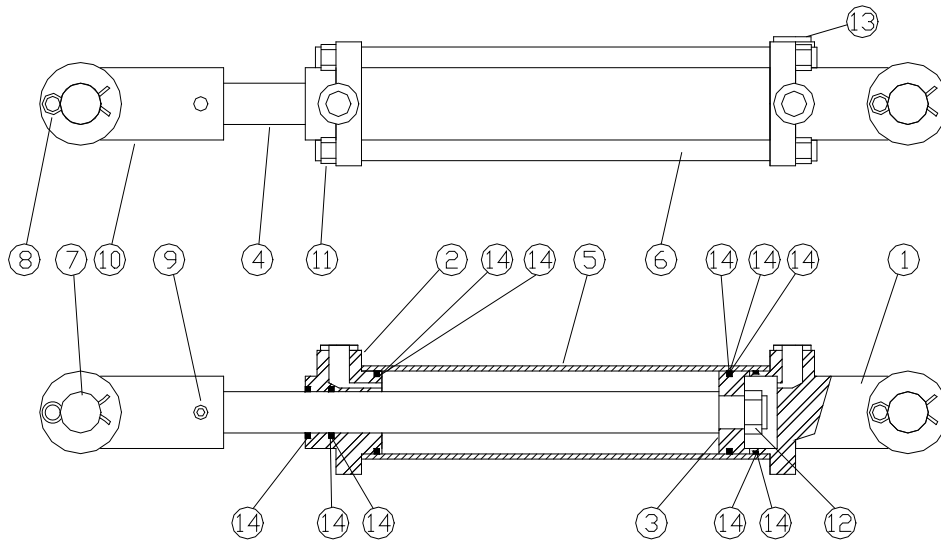

ITEM #	PART #	DESCRIPTION
1	492678	Clevis Cap 3-3/4" ORB
2	492679	Rod Cap 3-3/4" x 1-3/8" ORB
3	494732	Piston 3-3/4" TP
4	492800	Rod 1-3/8" Dia. ASAE 8
5	464268	Tube Weld 3-3/4" x 8" TP
6	492338	Tie Rod 5/8" x 8"
7	469528	Pin 1" Dia. For Cotter
8	135995	Cotter Pin 3/16" x 1-1/2" Hammerlock
9	148390	SC SCKT Set 3/8" UNC x 1/2" KNUR
10	492652	Rod Clevis 1-1/4"
11	128271	Nut Hex 5/8" UNF
12	130559	Nut Hex 1-1/8 UNF Gr.A Unitorque
13	186562	Plug 3/4" - 16 UNF SOC HD STR-THD
14	639563	Seal Kit 3-3/4" x 1-3/8"

PARTS DETAIL – CYLINDERS

MONARCH 4" X 8" BP (40TP08 - 137)

MONARCH PART NUMBER 639964

RITE WAY PART NUMBER 030-5740

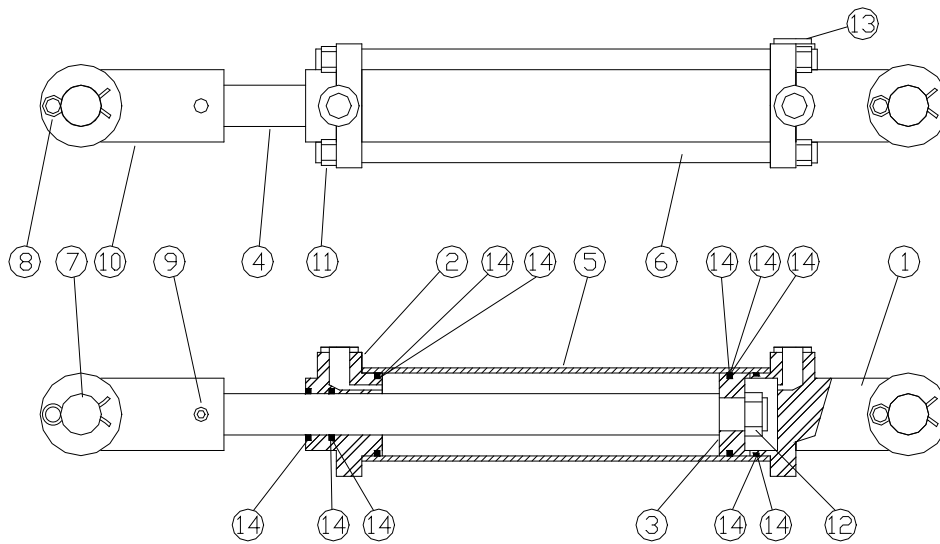

ITEM #	PART #	DESCRIPTION
1	492680	Clevis Cap 4" ORB
2	492685	Rod Cap 4" x 1-3/8" ORB
3	494730	Piston 4" TH/TP
4	492800	Rod 1-3/8" Dia. ASAE 8
5	464269	Tube Weld 4" x 8" TP
6	492338	Tie Rod 5/8" x 8"
7	469528	Pin 1" Dia. For Cotter
8	135995	Cotter Pin 3/16" x 1-1/2" Hammerlock
9	148390	SC SCKT Set 3/8" UNC x 1/2" KNUR
10	492652	Rod Clevis 1-1/4"
11	128271	Nut Hex 5/8" UNF
12	130559	Nut Hex 1-1/8" UNF Gr.A Uunitorque
13	186562	Plug 3/4" - 16 UNF SOC HD STR-THD
14	639564	Seal Kit 4" x 1-3/8"

PARTS DETAIL – CYLINDERS

MONARCH 2" X 12" (20TXC12 - 113)

MONARCH PART NUMBER 671624

RITE WAY PART NUMBER 030-5979

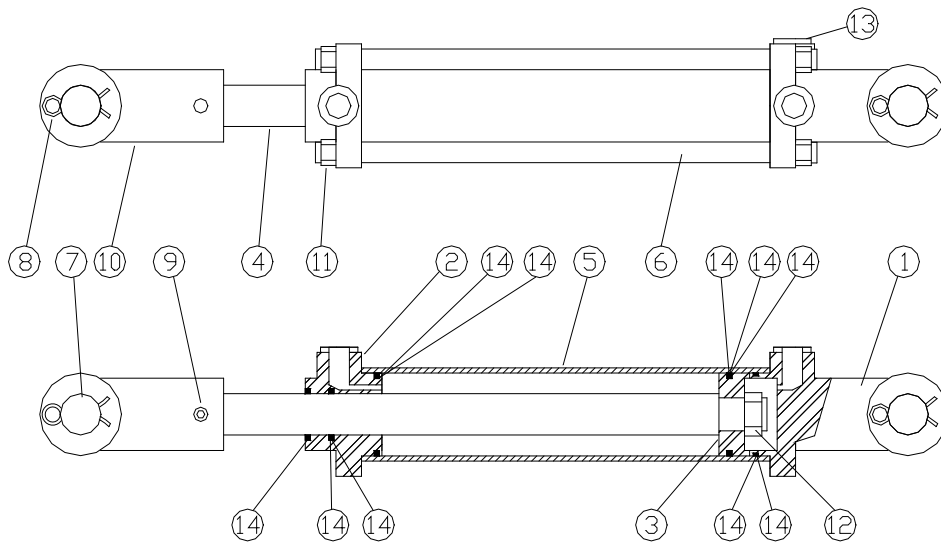

ITEM #	PART #	DESCRIPTION
1	492672	Clevis Cap 2" x 3/8" ORB-1.00
2	492665	Rod Cap 2" x 1-1/8" - 3/4" ORB
3	492548	Piston 2" Dia. CST DI
4	492853	Rod 1-1/8" x 12"
5	491612	Tube 2" x 12" Cylinder
6	492222	Tie Rod 3/8", 12" Cylinder
7	134953	Pin Ø1" x 3.37" for Cotter
8	134952	Hair Pin .105" Dia.
9	148390	SC SCKT Set, 3/8" UNC x 1/2" KNUR
10	492650	Rod Clevis 1-1/8" - 12 UNF
11	128230	Hex Nut 3/8" UNC Gr.5
12	129090	Hex Nut 3/4" UNF Gr.5
13	186562	Plug D 3/4"-16 SOC HD STR-THD
14	639572	Seal Kit - 2" x 1-1/8"

PARTS DETAIL – CYLINDERS

MONARCH 2" X 4" (20TX04-112)

MONARCH PART NUMBER 661838

RITE WAY PART NUMBER 030-5999

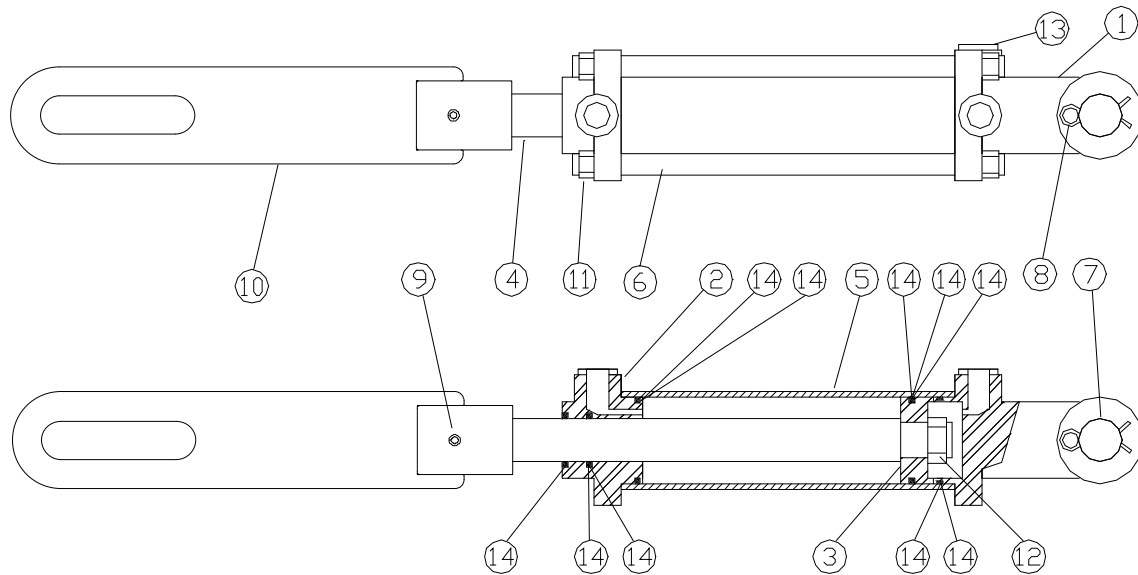

ITEM #	PART #	DESCRIPTION
1	492672	Clevis Cap 2" x 3/8" ORB-1.00
2	492665	Rod Cap 2" x 1-1/8" - 3/4" ORB
3	492548	Piston 2" Dia. CST DI
4	497505	Rod 1-1/8" x 8"
5	491604	Tube 2" x 4" Cylinder
6	492214	Tie Rod 3/8", 4" Cylinder
7	134953	Pin Ø1" x 3.37" for Cotter
8	134952	Hair Pin .105" Dia.
9	148390	SC SCKT Set, 3/8" UNC x 1/2" KNUR
10	105-1250	Rod Clevis, Slotted (SOLD WITH CYLINDER ONLY)
11	128230	Hex Nut 3/8" UNC Gr.5
12	129090	Hex Nut 3/4" UNF Gr.5
13	186562	Plug D 3/4"-16 SOC HD STR-THD
14	639572	Seal Kit - 2" x 1-1/8"

NOTES